

Aerial Cable Systems Components Catalog



Tight Spaces

Horizontal clearance is reduced by 2' to 5.5' with Aerial Spacer Cable



Heavily Treed Areas

Messenger provides strengths from 12,000 to 60,000 pounds



Long Spans

Highway and river crossings with installations as long as 1600'



Wildfire Mitigation

Substantial reduction in phase to phase or phase to ground contact



Ecologically Sensitive Areas

Ideal for National Parks, Wildlife Areas & Waterfowl/Migration habitats



Transmission

Build additional circuits in existing ROW and get easier and faster ROW approvals



Overbuilds/Underbuilds

Can fit up to 8 circuits on one pole



Renewable Energy

Improved voltage regulation by 20% and less ROW required



Substation Exits

Smaller footprint and less real estate needed



Industrial Applications

Significant reliability improvements, reduced clearances, and multiple circuits on a single pole



Product Type	Part Number	Description	Page #
Cable	S...	Covered Conductors - Spacer Cable Systems	2 - 7
		Spacer Cable Ampacity Tables	8 - 9
	T...	Covered Conductors - Tree Wire Systems	10 - 12
		Tree Wire Ampacity Tables	13 - 16
	S..., T...	90°C Covered Conductors - Spacer Cable Systems	17
Messenger	MSG...	Messenger Wire - Spacer Cable Systems	18
Tie Wire	TIE04...	Covered Tie Wire	19
Tap Wire	TAP...	Covered Tap Wire	20
Ground Wire	GW04	Insulated Ground Wire	21
Spacers	RTL-15/46/GO95	3 Phase Spacers	22
	RTL-20V/VDM/VXL	Single Phase Spacers	23
	RTL-69DM-01	69kV 3 Phase Spacer	24
	RTL-115	115kV 3 Phase Spacer	25
Brackets	BM-14, BM-24	Tangent Brackets	26
	BAS-14F/14S/24F	Anti-Sway Brackets	27 - 28
	TS-1, MC-2	Tangent Bracket Stirrup, Messenger Clamps	29
	MC-4	Messenger Clamp	30
	BA3-15, BA3-35	Angle Brackets	31
	BA4-15, BA4-35	Angle Brackets	32
	BA6-15	Angle Bracket	33
	BA6-15-25C	Horizontal Bracket	34
	BA1-PP	Pole Cornering Plate	35
	BD-35	Dead-End Bracket	36
	BV-35	Vertical Tap	37
	BT3-35	Transformer Tap Bracket	38
	PSAC-01	Stringing Angle Clamp	39
Hardware	CMA-1/2, UB-HD	Angle Clamps, U-Bolt	40
	2IP	Double Insulator Plate	41
	SSP-2, LSP-1	Insulator Pins	42
	SC, TC, HDTC	Clevises	43
	DEINS15/25/35	Polymer Dead-End Insulators	44
	XPT-30	Pole Top Extension	45
	XPT-60/60H/75/75H	Pole Top Extensions	46
	Grips and Splices	CG-0111 thru CG-0128	Conductor Dead-End Grips
MG / MS		Messenger Dead-End Grips / Splices	48
KM...		Cold Shrink Splice Cover Kits	49 - 51
Installation	PBR-3DR, QRS-02, TL-30	Roll By Block, Messenger Trolley, Tag Line	52
	QR-SLED-02	Quick Release Pulling Sled	53
	3SB-02	Three Sheave Stringing Block	54
	PAT-1	Angle Tensioning Block	55
	PAS-1	Angle Stringing Block	56
	BJ	Slack Bracket	57
	CMC-2	Underarm Messenger Clamp	58
	ST2900, WS	Stripping Tools	59
	PGA	Pulling Grip Assembly	60
	MSG-PULL-GRIP-ASY	Messenger Pulling Grip Assembly	61
	AMB	Aerial Messenger Bucket	62
	SG-1	Sag Gauge	63
	ACS-EQP...	Aerial Installation Trailer	64

Covered Conductors - Spacer Cable Systems



Description:

Covered conductors consist of stranded hard drawn aluminium conductors with three extruding layers where the total thickness depends on the voltage class. Covered conductors are available in black or gray depending on visual preference.

Benefits:

- Covering prevents faults due to contact
- Proprietary, high density outer layer resists abrasion, electrical tracking and UV degradation.
- Reduced NESC phase spacing is possible due to high impulse strength covering.
- Multiple circuits can be added on existing right of way

Application:

Covered conductors are designed to be used in spacer cable systems. Conductors are suspended from the messenger using Hendrix polyethylene spacers. Covered conductors are rated for continuous operation at 75°C.

15kV

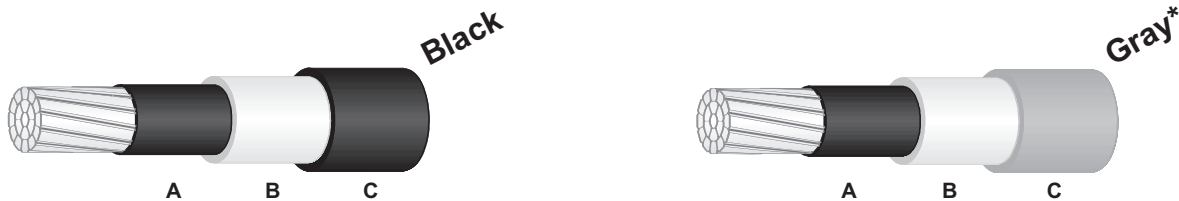

- A** 0.015" Semiconducting Polyethylene (0.020" for 477 kcmil and larger)
- B** 0.075" Natural Low Density Polyethylene (0.080" for 795 kcmil)
- C** 0.075" Black or Gray Track Resistant High Density Polyethylene (0.080" for 795 kcmil)

Catalog Number	Size	Strands	Type	Conductor Diameter (in)	Finished Cable Diameter (in)	Cable Weight (lbs/1000 ft)
S0010PA15B3-00	1/0 AWG	7	Compact	0.336	0.666	215
S0020PA15B3-00	2/0 AWG	7	Compact	0.376	0.706	251
S0030PA15B3-00	3/0 AWG	7	Compact	0.423	0.753	297
S0040PA15B3-00	4/0 AWG	7	Compact	0.475	0.805	351
S0266PA15B3-00	266.8 kcmil	7	Compact	0.537	0.867	416
S0336PA15B3-00	336.4 kcmil	19	Compact	0.603	0.933	497
S0397PA15B3-00	397.5 kcmil	19	Compact	0.659	0.989	568
S0477PA15B3-00	477.0 kcmil	19	Compact	0.722	1.062	662
S0556PA15B3-00	556.5 kcmil	19	Compact	0.780	1.120	752
S0636PA15B3-00	636.0 kcmil	19	Compact	0.835	1.175	839
S0795PA15B3-00	795.0 kcmil	19	Compact	0.932	1.292	1,049

*Substitute G for B in the catalog number for a Gray outer layer
Conductor sizes not shown may be available upon request.

continued

Covered Conductors - Spacer Cable Systems



25kV

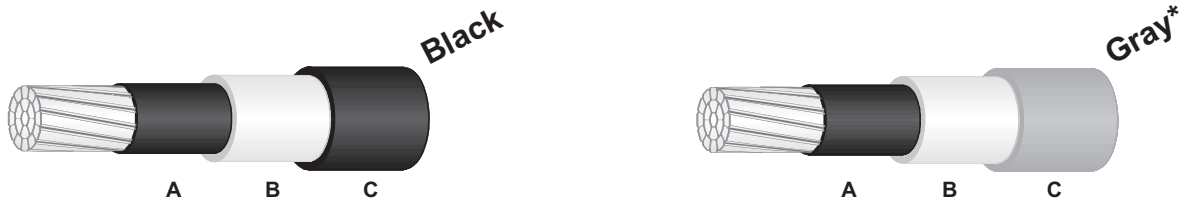

- A 0.015" Semiconducting Polyethylene (0.020" for 477 kcmil and larger)
- B 0.125" Natural Low Density Polyethylene
- C 0.125" Black or Gray Track Resistant High Density Polyethylene

Catalog Number	Size	Strands	Type	Conductor Diameter (in)	Finished Cable Diameter (in)	Cable Weight (lbs/1000 ft)
S0010PA25B3-00	1/0 AWG	7	Compact	0.336	0.866	321
S0020PA25B3-00	2/0 AWG	7	Compact	0.376	0.906	363
S0030PA25B3-00	3/0 AWG	7	Compact	0.423	0.953	414
S0040PA25B3-00	4/0 AWG	7	Compact	0.475	1.005	476
S0266PA25B3-00	266.8 kcmil	7	Compact	0.537	1.067	550
S0336PA25B3-00	336.4 kcmil	19	Compact	0.603	1.133	640
S0397PA25B3-00	397.5 kcmil	19	Compact	0.659	1.189	718
S0477PA25B3-00	477.0 kcmil	19	Compact	0.722	1.262	815
S0556PA25B3-00	556.5 kcmil	19	Compact	0.780	1.32	912
S0636PA25B3-00	636.0 kcmil	19	Compact	0.835	1.375	1,005
S0795PA25B3-00	795.0 kcmil	19	Compact	0.932	1.472	1,211

*Substitute G for B in the catalog number for a Gray outer layer
Conductor sizes not shown may be available upon request.

continued

Covered Conductors - Spacer Cable Systems



35kV



- A 0.015" Semiconducting Polyethylene (0.020" for 477 kcmil and larger)
- B 0.175" Natural Low Density Polyethylene
- C 0.125" Black or Gray Track Resistant High Density Polyethylene

Catalog Number	Size	Strands	Type	Conductor Diameter (in)	Finished Cable Diameter (in)	Cable Weight (lbs/1000 ft)
S0010PA35B3-00	1/0 AWG	7	Compact	0.336	0.966	384
S0020PA35B3-00	2/0 AWG	7	Compact	0.376	1.006	429
S0030PA35B3-00	3/0 AWG	7	Compact	0.423	1.053	483
S0040PA35B3-00	4/0 AWG	7	Compact	0.475	1.105	548
S0266PA35B3-00	266.8 kcmil	7	Compact	0.537	1.167	625
S0336PA35B3-00	336.4 kcmil	19	Compact	0.603	1.233	721
S0397PA35B3-00	397.5 kcmil	19	Compact	0.659	1.289	803
S0477PA35B3-00	477.0 kcmil	19	Compact	0.722	1.362	903
S0556PA35B3-00	556.5 kcmil	19	Compact	0.780	1.42	1,004
S0636PA35B3-00	636.0 kcmil	19	Compact	0.835	1.475	1,102
S0795PA35B3-00	795.0 kcmil	19	Compact	0.932	1.572	1,315

*Substitute G for B in the catalog number for a Gray outer layer
Conductor sizes not shown may be available upon request.

continued

Covered Conductors - Spacer Cable Systems



46kV

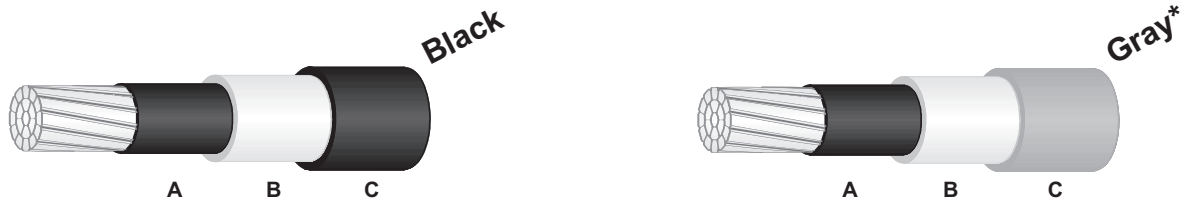

- A** 0.015" Semiconducting Polyethylene (0.020" for 477 kcmil and larger)
- B** 0.225" Natural Low Density Polyethylene
- C** 0.175" Black or Gray Track Resistant High Density Polyethylene

Catalog Number	Size	Strands	Type	Conductor Diameter (in)	Finished Cable Diameter (in)	Cable Weight (lbs/1000 ft)
S0010PA46B3-00	1/0 AWG	7	Compact	0.336	1.166	509
S0020PA46B3-00	2/0 AWG	7	Compact	0.376	1.206	557
S0030PA46B3-00	3/0 AWG	7	Compact	0.423	1.253	616
S0040PA46B3-00	4/0 AWG	7	Compact	0.475	1.305	687
S0266PA46B3-00	266.8 kcmil	7	Compact	0.537	1.367	773
S0336PA46B3-00	336.4 kcmil	19	Compact	0.603	1.433	874
S0397PA46B3-00	397.5 kcmil	19	Compact	0.659	1.489	963
S0477PA46B3-00	477.0 kcmil	19	Compact	0.722	1.562	1,091
S0556PA46B3-00	556.5 kcmil	19	Compact	0.780	1.620	1,198
S0636PA46B3-00	636.0 kcmil	19	Compact	0.835	1.675	1,314
S0795PA46B3-00	795.0 kcmil	19	Compact	0.932	1.772	1,511

*Substitute G for B in the catalog number for a Gray outer layer
Conductor sizes not shown may be available upon request.

Covered Conductors - Spacer Cable Systems



69kV

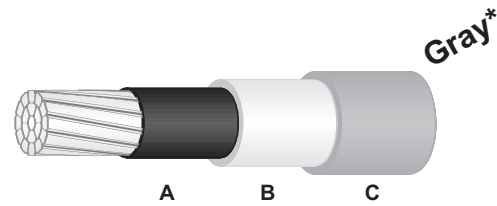
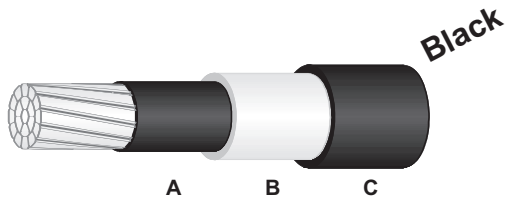

- A** 0.015" Semiconducting Polyethylene (0.020" for 477 kcmil and larger)
- B** 0.250" Natural Low Density Thermoplastic Polyethylene
- C** 0.250" Grey or Black Track Resistant High Density Thermoplastic Polyethylene

Catalog Number	Size	Strands	Type	Conductor Diameter (in)	Finished Cable Diameter (in)	Cable Weight (lbs/1000 ft)
S0336PA69G3-00	336.4 kcmil	19	Compact	0.603	1.633	1,065
S0397PA69G3-00	397.5 kcmil	19	Compact	0.659	1.689	1,164
S0477PA69G3-00	477.0 kcmil	19	Compact	0.722	1.762	1,293
S0556PA69G3-00	556.5 kcmil	19	Compact	0.780	1.820	1,407
S0636PA69G3-00	636.0 kcmil	19	Compact	0.835	1.875	1,520
S0795PA69G3-00	795.0 kcmil	19	Compact	0.932	1.972	1,735
S0954PA69G3-00	954.0 kcmil	37	Compact	1.024	2.064	1,948

*Substitute B for G in the catalog number for a Black outer layer
Conductor sizes not shown may be available upon request.

Covered Conductors - Spacer Cable Systems



115kV



- A** 0.015" Semiconducting Polyethylene (0.020" for 477 kcmil and larger)
- B** 0.250" Natural Low Density Thermoplastic Polyethylene
- C** 0.250" Gray or Black Track Resistant High Density Thermoplastic Polyethylene

Catalog Number	Size	Strands	Type	Conductor Diameter (in)	Finished Cable Diameter (in)	Cable Weight (lbs/1000 ft)
S0336PA69G3-00	336.4 kcmil	19	Compact	0.603	1.633	1,065
S0397PA69G3-00	397.5 kcmil	19	Compact	0.659	1.689	1,164
S0477PA69G3-00	477.0 kcmil	19	Compact	0.722	1.762	1,293
S0556PA69G3-00	556.5 kcmil	19	Compact	0.780	1.820	1,407
S0636PA69G3-00	636.0 kcmil	19	Compact	0.835	1.875	1,520
S0795PA69G3-00	795.0 kcmil	19	Compact	0.932	1.972	1,735
S0954PA69G3-00	954.0 kcmil	37	Compact	1.024	2.064	1,948

*Substitute B for G in the catalog number for a Black outer layer
Conductor sizes not shown may be available upon request.

Spacer Cable Ampacity Table - AAC 75°C Conductors



75°C Black Conductors

Conductor Size	15 kV		25 kV		35kV		46 kV		69 kV	
	Normal ¹	Emergency ²	Normal ¹	Emergency ²	Normal ¹	Emergency ²	Normal ¹	Emergency ²	Normal ¹	Emergency ²
1/0 AWG	232	289	225	280	221	276	215	269	-	-
2/0 AWG	267	332	258	322	254	318	246	309	-	-
3/0 AWG	307	383	297	371	292	366	283	356	-	-
4/0 AWG	354	442	341	428	335	421	325	410	315	399
266.8 KCM	408	511	393	494	386	486	374	472	363	460
336.4 KCM	470	590	453	570	445	561	430	544	417	530
397.5 KCM	522	656	502	633	493	622	477	604	462	587
477.0 KCM	582	734	560	707	550	696	532	675	516	656
556.5 KCM	639	807	615	778	604	765	584	742	566	722
636.0 KCM	695	879	667	846	655	831	633	806	614	783
795.0 KCM	793	1006	764	971	750	954	724	924	702	898

¹Normal Ampacity @ 75°C Conductor Temperature, 25°C Ambient Temperature, 2 ft/sec Wind, Sun

²Emergency Ampacity @ 100°C Conductor Temperature, 25°C Ambient Temperature, 2 ft/sec Wind, Sun

Hendrix Cable will not suffer plastic flow from short term (48 hours) overloads up to 100°C Conductor Temperature

75°C Gray Conductors

Conductor Size	15 kV		25 kV		35kV		46 kV		69 kV	
	Normal ¹	Emergency ²	Normal ¹	Emergency ²	Normal ¹	Emergency ²	Normal ¹	Emergency ²	Normal ¹	Emergency ²
1/0 AWG	235	286	230	280	227	277	222	271	-	-
2/0 AWG	270	329	264	321	260	318	254	311	-	-
3/0 AWG	311	378	303	370	299	365	292	258	-	-
4/0 AWG	358	436	348	425	344	420	336	411	328	402
266.8 KCM	413	504	401	491	396	485	386	474	377	463
336.4 KCM	475	581	462	565	456	558	444	545	433	533
397.5 KCM	527	645	512	627	505	619	392	604	479	590
477.0 KCM	588	721	571	701	563	691	548	674	535	660
556.5 KCM	645	792	627	770	618	760	602	741	587	724
636.0 KCM	702	862	680	836	670	825	652	804	636	786
795.0 KCM	801	986	778	959	767	945	746	921	727	900

¹Normal Ampacity @ 75°C Conductor Temperature, 25°C Ambient Temperature, 2 ft/sec Wind, Sun

²Emergency Ampacity @ 100°C Conductor Temperature, 25°C Ambient Temperature, 2 ft/sec Wind, Sun

Hendrix Cable will not suffer plastic flow from short term (48 hours) overloads up to 100°C Conductor Temperature

continued

Spacer Cable Ampacity Table - AAC 90°C Conductors



90°C Black Conductors

Conductor Size	15 kV		25 kV		35kV		46 kV		69 kV	
	Normal ¹	Emergency ²	Normal ¹	Emergency ²	Normal ¹	Emergency ²	Normal ¹	Emergency ²	Normal ¹	Emergency ²
1/0 AWG	268	307	260	298	257	294	250	287	-	-
2/0 AWG	309	353	299	343	295	338	287	329	-	-
3/0 AWG	356	407	344	395	339	389	330	379	-	-
4/0 AWG	410	470	397	455	391	448	379	436	369	425
266.8 KCM	474	544	458	526	450	518	437	503	425	490
336.4 KCM	547	629	528	607	519	597	504	580	490	565
397.5 KCM	608	699	586	674	576	663	558	644	543	626
477.0 KCM	679	783	654	754	643	742	624	720	606	701
556.5 KCM	746	861	720	830	707	816	685	792	666	770
636.0 KCM	819	938	782	903	768	887	744	860	723	837
795.0 KCM	929	1075	897	1037	881	1019	853	987	828	959

¹Normal Ampacity @ 90°C Conductor Temperature, 25°C Ambient Temperature, 2 ft/sec Wind, Sun

²Emergency Ampacity @ 110°C Conductor Temperature, 25°C Ambient Temperature, 2 ft/sec Wind, Sun

Hendrix Cable will not suffer plastic flow from short term (48 hours) overloads up to 110°C Conductor Temperature

90°C Gray Conductors

Conductor Size	15 kV		25 kV		35kV		46 kV		69 kV	
	Normal ¹	Emergency ²	Normal ¹	Emergency ²	Normal ¹	Emergency ²	Normal ¹	Emergency ²	Normal ¹	Emergency ²
1/0 AWG	268	302	262	296	259	293	253	287	-	-
2/0 AWG	308	347	300	340	297	336	291	329	-	-
3/0 AWG	354	400	346	391	342	387	334	378	-	-
4/0 AWG	408	461	398	450	393	445	384	435	376	426
266.8 KCM	471	533	458	519	453	513	442	502	432	491
336.4 KCM	543	615	528	599	521	591	509	578	497	565
397.5 KCM	602	683	585	664	578	656	564	640	551	626
477.0 KCM	673	764	654	742	645	733	629	715	615	699
556.5 KCM	739	839	718	816	709	805	691	786	675	768
636.0 KCM	804	914	780	887	769	875	750	853	732	834
795.0 KCM	919	1046	894	1017	881	1003	858	977	838	955

¹Normal Ampacity @ 90°C Conductor Temperature, 25°C Ambient Temperature, 2 ft/sec Wind, Sun

²Emergency Ampacity @ 110°C Conductor Temperature, 25°C Ambient Temperature, 2 ft/sec Wind, Sun

Hendrix Cable will not suffer plastic flow from short term (48 hours) overloads up to 110°C Conductor Temperature

Covered Conductors - Tree Wire Systems



Description:

Tree wire or covered open wire consists of the conductor (aluminum, aluminum alloy or ACSR) and the extruded covering (conductor shield, low density inner layer and protective outer layer). Covering thickness depends on the system voltage. It is designed for full span applications and is supported on polyethylene insulators. We also offer a two layer covered conductor design for 15kV systems that are not subject to heavy tree contact. Covered conductors are available in black or gray depending on visual preference.

Benefits:

- Covering prevents faults due to contact
- Proprietary, high density outer layer resists abrasion, electrical tracking and UV degradation.
- Reduced NESC phase spacing is possible due to high impulse strength covering.
- Pole hardware is the same as bare wire construction except that Hendrix polyethylene insulators are required.

Application:

Hendrix provides tree wire designed for systems from 15kV through 46kV. Polyethylene insulators must be used to insure dielectric compatibility with conductor covering. Conductors are supported on crossarms or standoff brackets. Span lengths are limited by the conductor breaking strength and the amount of sag that is permissible. Covered conductors are rated for continuous operation at 75°C. (Consult Hendrix sales representative for 46kV tree wire systems).

15kV Tree Wire

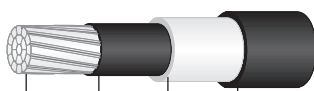

0.075" black or gray high density polyethylene (0.080" for 795 kcmil)

0.075" natural linear low density polyethylene (0.080" for 795 kcmil)

0.015" black semiconducting polyethylene (0.020" for 477 kcmil and larger)

25kV Tree Wire

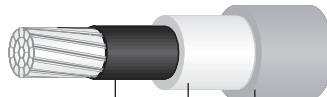

0.125" black or gray high density polyethylene

0.125" natural linear low density polyethylene

0.015" black semiconducting polyethylene (0.020" for 477 kcmil and larger)

35kV Tree Wire

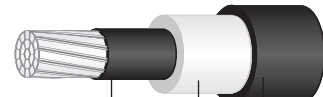

0.125" black or gray high density polyethylene

0.175" natural linear low density polyethylene

0.015" black semiconducting polyethylene (0.020" for 477 kcmil and larger)

Aluminum, Aluminum Alloy or ACSR (copper, AWAC, ACAR conductors are also available)

continued

Covered Conductors - Tree Wire Systems



ACSR Concentric Round Conductors*

15kV

Part Number	Size	Code Word	Strands (Al/Steel)	15kV Tree Wire	
				Conductor Diameter (in)	Cable Weight (lbs/1000 ft)
T0010RR15B3-00	1/0 AWG	Raven	6/1	0.728	284
T0020RR15B3-00	2/0 AWG	Quail	6/1	0.777	336
T0030RR15B3-00	3/0 AWG	Pigeon	6/1	0.832	400
T0040RR15B3-00	4/0 AWG	Penguin	6/1	0.893	478
T0266RR15B3-00	266.8 kcmil	Waxwing	18/1	0.939	480
T0336RR15B3-00	336.4 kcmil	Merlin	18/1	1.014	576
T0397RR15B3-00	397.5 kcmil	Chickadee	18/1	1.073	660
T0477RR15B3-00	477.0 kcmil	Pelican	18/1	1.154	775

25kV

Part Number	Size	Code Word	Strands (Al/Steel)	25kV Tree Wire	
				Conductor Diameter (in)	Cable Weight (lbs/1000 ft)
T0010RR25B3-00	1/0 AWG	Raven	6/1	0.928	391
T0020RR25B3-00	2/0 AWG	Quail	6/1	0.977	450
T0030RR25B3-00	3/0 AWG	Pigeon	6/1	1.032	521
T0040RR25B3-00	4/0 AWG	Penguin	6/1	1.093	607
T0266RR25B3-00	266.8 kcmil	Waxwing	18/1	1.139	615
T0336RR25B3-00	336.4 kcmil	Merlin	18/1	1.214	720
T0397RR25B3-00	397.5 kcmil	Chickadee	18/1	1.273	812
T0477RR25B3-00	477.0 kcmil	Pelican	18/1	1.354	938

35kV

Part Number	Size	Code Word	Strands (Al/Steel)	35kV Tree Wire	
				Conductor Diameter (in)	Cable Weight (lbs/1000 ft)
T0010RR35B3-00	1/0 AWG	Raven	6/1	1.028	454
T0020RR35B3-00	2/0 AWG	Quail	6/1	1.077	516
T0030RR35B3-00	3/0 AWG	Pigeon	6/1	1.132	591
T0040RR35B3-00	4/0 AWG	Penguin	6/1	1.193	681
T0266RR35B3-00	266.8 kcmil	Waxwing	18/1	1.239	691
T0336RR35B3-00	336.4 kcmil	Merlin	18/1	1.314	802
T0397RR35B3-00	397.5 kcmil	Chickadee	18/1	1.373	897
T0477RR35B3-00	477.0 kcmil	Pelican	18/1	1.454	1,028

*Conductor selection must be based on rated breaking strength, span length and regional loading conditions. Conductor sizes not shown may be available upon request.

continued

Covered Conductors - Tree Wire Systems



Aluminum Alloy (6201-T81) Concentric Round Conductors

15kV

Part Number	Size	Code Word	15kV Tree Wire	
			Conductor Diameter (in)	Cable Weight (lbs/1000 ft)
T0010RY15B3-00	1/0 AWG	Azusa	0.728	255
T0020RY15B3-00	2/0 AWG	Anaheim	0.777	299
T0030RY15B3-00	3/0 AWG	Amherst	0.832	353
T0040RY15B3-00	4/0 AWG	Alliance	0.893	419

25kV

Part Number	Size	Code Word	25kV Tree Wire	
			Conductor Diameter (in)	Cable Weight (lbs/1000 ft)
T0010RY25B3-00	1/0 AWG	Azusa	0.928	362
T0020RY25B3-00	2/0 AWG	Anaheim	0.977	413
T0030RY25B3-00	3/0 AWG	Amherst	1.032	474
T0040RY25B3-00	4/0 AWG	Alliance	1.093	548

35kV

Part Number	Size	Code Word	35kV Tree Wire	
			Conductor Diameter (in)	Cable Weight (lbs/1000 ft)
T0010RY35B3-00	1/0 AWG	Azusa	1.028	424
T0020RY35B3-00	2/0 AWG	Anaheim	1.077	478
T0030RY35B3-00	3/0 AWG	Amherst	1.132	543
T0040RY35B3-00	4/0 AWG	Alliance	1.193	621

Conductor sizes not shown may be available upon request.

Tree Wire Ampacity Table - ACSR 75°C Conductors



75°C Black Conductors

Conductor Size	Code Name	15 kV		25 kV		35kV	
		Normal ¹	Emergency ²	Normal ¹	Emergency ²	Normal ¹	Emergency ²
1/0 AWG	Raven	241	300	233	291	229	287
2/0 AWG	Quail	277	346	268	335	263	330
3/0 AWG	Pigeon	320	400	308	386	303	380
4/0 AWG	Penguin	386	461	354	446	348	439
266.8 KCM	Waxwing	421	528	405	510	398	502
336.4 KCM	Merlin	485	611	467	589	458	579
397.5 KCM	Chickadee	538	678	517	653	507	642
477.0 KCM	Pelican	602	760	577	730	566	718

¹Normal Ampacity @ 75°C Conductor Temperature, 25°C Ambient Temperature, 2 ft/sec Wind, Sun

²Emergency Ampacity @ 100°C Conductor Temperature, 25°C Ambient Temperature, 2 ft/sec Wind, Sun

Hendrix Cable will not suffer plastic flow from short term (48 hours) overloads up to 100°C Conductor Temperature

75°C Gray Conductors

Conductor Size	Code Name	15 kV		25 kV		35kV	
		Normal ¹	Emergency ²	Normal ¹	Emergency ²	Normal ¹	Emergency ²
1/0 AWG	Raven	244	297	238	290	235	287
2/0 AWG	Quail	281	342	273	334	270	330
3/0 AWG	Pigeon	323	394	314	384	310	380
4/0 AWG	Penguin	372	454	362	442	357	437
266.8 KCM	Waxwing	425	520	413	506	407	499
336.4 KCM	Merlin	490	600	476	583	469	576
397.5 KCM	Chickadee	543	665	526	646	519	638
477.0 KCM	Pelican	607	745	588	723	580	713

¹Normal Ampacity @ 75°C Conductor Temperature, 25°C Ambient Temperature, 2 ft/sec Wind, Sun

²Emergency Ampacity @ 100°C Conductor Temperature, 25°C Ambient Temperature, 2 ft/sec Wind, Sun

Hendrix Cable will not suffer plastic flow from short term (48 hours) overloads up to 100°C Conductor Temperature

Tree Wire Ampacity Table - ACSR 90°C Conductors



90°C Black Conductors

Conductor Size	Code Name	15 kV		25 kV		35kV	
		Normal ¹	Emergency ²	Normal ¹	Emergency ²	Normal ¹	Emergency ²
1/0 AWG	Raven	279	319	270	310	266	305
2/0 AWG	Quail	321	368	315	362	311	357
3/0 AWG	Pigeon	371	425	358	411	353	405
4/0 AWG	Penguin	428	491	413	475	406	467
266.8 KCM	Waxwing	490	563	472	543	464	534
336.4 KCM	Merlin	566	651	545	628	536	617
397.5 KCM	Chickadee	627	723	604	696	594	685
477.0 KCM	Pelican	703	811	677	781	665	767

¹Normal Ampacity @ 90°C Conductor Temperature, 25°C Ambient Temperature, 2 ft/sec Wind, Sun

²Emergency Ampacity @ 110°C Conductor Temperature, 25°C Ambient Temperature, 2 ft/sec Wind, Sun

Hendrix Cable will not suffer plastic flow from short term (48 hours) overloads up to 110°C Conductor Temperature

90°C Gray Conductors

Conductor Size	Code Name	15 kV		25 kV		35kV	
		Normal ¹	Emergency ²	Normal ¹	Emergency ²	Normal ¹	Emergency ²
1/0 AWG	Raven	278	314	271	307	268	303
2/0 AWG	Quail	320	362	312	353	308	349
3/0 AWG	Pigeon	368	417	359	407	355	402
4/0 AWG	Penguin	425	481	413	468	408	463
266.8 KCM	Waxwing	486	550	472	536	466	529
336.4 KCM	Merlin	560	636	544	618	537	610
397.5 KCM	Chickadee	621	705	603	685	595	676
477.0 KCM	Pelican	695	790	675	767	665	756

¹Normal Ampacity @ 90°C Conductor Temperature, 25°C Ambient Temperature, 2 ft/sec Wind, Sun

²Emergency Ampacity @ 110°C Conductor Temperature, 25°C Ambient Temperature, 2 ft/sec Wind, Sun

Hendrix Cable will not suffer plastic flow from short term (48 hours) overloads up to 110°C Conductor Temperature

Tree Wire Ampacity Table - AAAC 75°C Conductors



75°C Black Conductors

Equivelant Conductor Size	Code Name	Actual Size	15 kV		25 kV		35kV	
			Normal ¹	Emergency ²	Normal ¹	Emergency ²	Normal ¹	Emergency ²
#2 AWG	Ames	77.47 KCM	182	226	—	—	—	—
1/0 AWG	Azuza	123.3 KCM	241	300	233	291	229	287
2/0 AWG	Anaheim	155.4 KCM	278	346	268	335	263	330
3/0 AWG	Amherst	195.7 KCM	334	418	308	386	303	381
4/0 AWG	Alliance	246.9 KCM	368	462	355	446	348	439

¹Normal Ampacity @ 75°C Conductor Temperature, 25°C Ambient Temperature, 2 ft/sec Wind, Sun

²Emergency Ampacity @ 100°C Conductor Temperature, 25°C Ambient Temperature, 2 ft/sec Wind, Sun

Hendrix Cable will not suffer plastic flow from short term (48 hours) overloads up to 100°C Conductor Temperature

75°C Gray Conductors

Equivelant Conductor Size	Code Name	Actual Size	15 kV		25 kV		35kV	
			Normal ¹	Emergency ²	Normal ¹	Emergency ²	Normal ¹	Emergency ²
#2 AWG	Ames	77.47 KCM	185	210	—	—	—	—
1/0 AWG	Azuza	123.3 KCM	244	297	238	290	235	287
2/0 AWG	Anaheim	155.4 KCM	281	342	274	334	270	330
3/0 AWG	Amherst	195.7 KCM	338	412	314	384	310	380
4/0 AWG	Alliance	246.9 KCM	372	455	362	443	357	437

¹Normal Ampacity @ 75°C Conductor Temperature, 25°C Ambient Temperature, 2 ft/sec Wind, Sun

²Emergency Ampacity @ 100°C Conductor Temperature, 25°C Ambient Temperature, 2 ft/sec Wind, Sun

Hendrix Cable will not suffer plastic flow from short term (48 hours) overloads up to 100°C Conductor Temperature

Tree Wire Ampacity Table - AAAC 90°C Conductors



90°C Black Conductors

Equivelant Conductor Size	Code Name	Actual Size	15 kV		25 kV		35kV	
			Normal ¹	Emergency ²	Normal ¹	Emergency ²	Normal ¹	Emergency ²
#2 AWG	Ames	77.47 KCM	210	240	—	—	—	—
1/0 AWG	Azuza	123.3 KCM	279	319	270	310	266	305
2/0 AWG	Anaheim	155.4 KCM	322	369	311	357	306	352
3/0 AWG	Amherst	195.7 KCM	388	445	358	411	353	405
4/0 AWG	Alliance	246.9 KCM	428	491	413	475	406	467

¹Normal Ampacity @ 90°C Conductor Temperature, 25°C Ambient Temperature, 2 ft/sec Wind, Sun

²Emergency Ampacity @ 110°C Conductor Temperature, 25°C Ambient Temperature, 2 ft/sec Wind, Sun

Hendrix Cable will not suffer plastic flow from short term (48 hours) overloads up to 110°C Conductor Temperature

90°C Gray Conductors

Equivelant Conductor Size	Code Name	Actual Size	15 kV		25 kV		35kV	
			Normal ¹	Emergency ²	Normal ¹	Emergency ²	Normal ¹	Emergency ²
#2 AWG	Ames	77.47 KCM	210	237	—	—	—	—
1/0 AWG	Azuza	123.3 KCM	278	314	271	307	268	304
2/0 AWG	Anaheim	155.4 KCM	320	362	312	353	308	349
3/0 AWG	Amherst	195.7 KCM	386	436	359	407	355	402
4/0 AWG	Alliance	246.9 KCM	425	481	414	469	408	463

¹Normal Ampacity @ 90°C Conductor Temperature, 25°C Ambient Temperature, 2 ft/sec Wind, Sun

²Emergency Ampacity @ 110°C Conductor Temperature, 25°C Ambient Temperature, 2 ft/sec Wind, Sun

Hendrix Cable will not suffer plastic flow from short term (48 hours) overloads up to 110°C Conductor Temperature

Description:

Hendrix 90°C overhead covered conductors are a higher ampacity alternative to 75°C spacer cable and tree wire. The semiconducting conductor shield is compatible with the 90°C rating. These covered conductors are available in the full range of voltage ratings and conductor sizes offered for 75°C covered conductors used in spacer cable and tree wire systems.

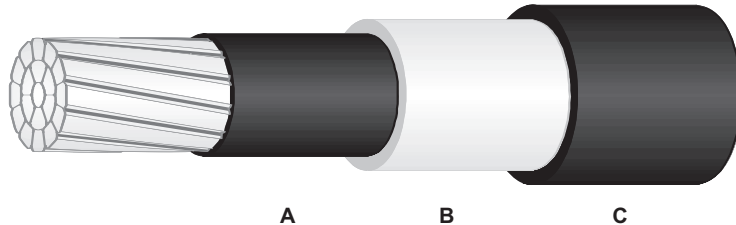

- A Semiconducting conductor shield
- B Unfilled high density polyethylene
- C Black or gray, high density polyethylene

Benefits:

- Approximately 14% increase in ampacity over 75°C cable
- Approaches ampacity of equivalent size bare wire
- Ideal for applications having seasonal short duration peak loading
- Potential savings due to reduced pole class and guying requirements
- Semiconducting conductor shield enhances the cable electrical properties
- Covering prevents faults due to contact.
- Proprietary, high density outer layer resists abrasion, electrical tracking and UV degradation.
- Compact

Application:

Hendrix 90°C covered conductors are designed for use on 15kV through 69kV spacer cable and tree wire systems. They are designed for sustained periods of operation at a 90°C conductor operating temperature. The resulting increase in ampacity may allow for the use of a smaller conductor size and provide savings in pole class and guying requirements. Also, the need for replacement of existing poles may be avoided. For assistance in selecting 90°C covered conductors for specific applications, please contact your Hendrix sales representative.

Messenger Wire - Spacer Cable Systems



Description:

Messenger wire is the support member of the Hendrix Spacer Cable System. Two types of messenger wires are available. Alumoweld-Aluminum (AWA) messenger wire has aluminum clad steel strands and 1350-H19 all aluminum strands. Alumoweld (AW) messenger wire has all strands made of aluminum clad steel.

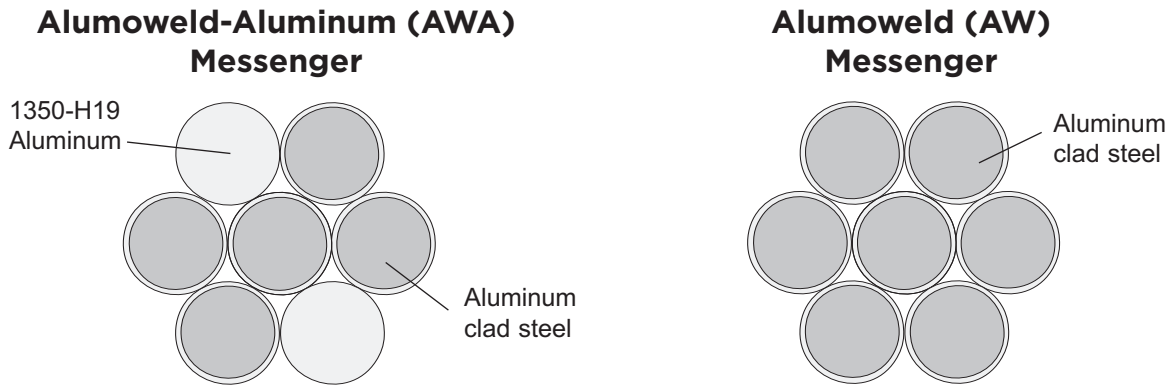

Benefits:

- Provides protection from falling branches
- May be used as the system neutral
- Provides lightning protection when properly grounded
- Better corrosion resistance than galvanized steel wire

Application:

AWA messenger is recommended in most cases because it has high strength and high conductivity. AW messenger is recommended when a higher strength messenger is needed. Messenger wire is pulled in and tensioned prior to conductor installation.

Physical & Electrical Data:

Part Number	Messenger Size	Equivalent Conductivity	Ampacity* (amps)	Overall Diameter (in)	Alumoweld Wires	Aluminum Wires	Weight (lbs/1000 ft)	Breaking Strength (lbs)
					No. x dia. (in)	No. x dia. (in)		
MSG052AWA007-01	052 AWA	1/0 AL	253	0.486	5 x 0.1620	2 x 0.1620	346	17,120
MSG0706AW007-01	7 No. 6 AW	#2 AL	201	0.486	7 x 0.1620	—	416	22,730
MSG0052AA007-01	0052 AWA	2/0 AL	292	0.546	5 x 0.1819	2 x 0.1819	436	20,420
MSG0127AA019-01	0000127 AWA	4/0 AL	431	0.722	12 x 0.1443	7 x 0.1443	699	32,670
MSG1908AW019-01	19 No. 8 AW	1/0 AL	283	0.642	19 x 0.1285	—	714	43,240

*Assumptions for ampacity calculations- 75°C Conductor Temperature, 25°C Ambient Temperature, 2 ft/sec (0.6096 m/s) Wind, Sun

Description:

Covered tie wire consists of a #4 AWG solid, fully annealed aluminum conductor covered by a 0.045" extruded layer of black thermoplastic rubber (TPE).



Benefits:

- Eliminates tracking and erosion caused by the use of bare tie wire on a covered conductor
- Conductor and covering are flexible and have no tendency to "springback"
- TPE covered tie wire grips covered conductor better than PVC and other tie wires

Application:

Covered tie wire is used to tie a covered conductor to a Hendrix polyethylene pin type insulator. The tying method is the same as that used with bare conductors and ties. Conductor covering should not be removed.

Thermoplastic Elastomer

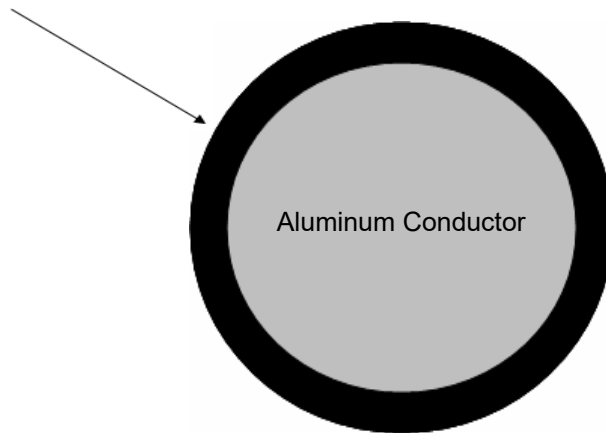

Catalog No.	Outside Diameter	Weight (lb/ft)	Standard Packaging
TIE04ALSOL-00	0.30	0.053	500 ft. hand coils (25 lbs.)

Description:

Hendrix tap wire is a copper conductor covered with a 0.150" layer of flexible, black, thermoplastic elastomer. It provides a covered lead from primary phase conductors to equipment bushings.

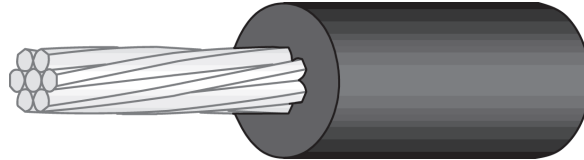

Benefits:

- Tap wire will reduce or eliminate outages due to wildfire contact
- Excellent ultraviolet and weathering characteristics maintain covering integrity
- Thermoplastic elastomer covering is more flexible and trains easier than polyethylene covering

Application:

Hendrix covered tap wire is used to connect an overhead phase conductor to equipment bushings. Using covered tap wire avoids outages due to wildlife contact with the energized tap and another phase or a ground plane such as a transformer case. Covered tap wire is commonly used with the Hendrix Wildlife Guard which is placed over the bushing and isolates the bushing connector from contact. The tap wire can also be used in substation equipment connections to provide covered bus and as covered ground lead.

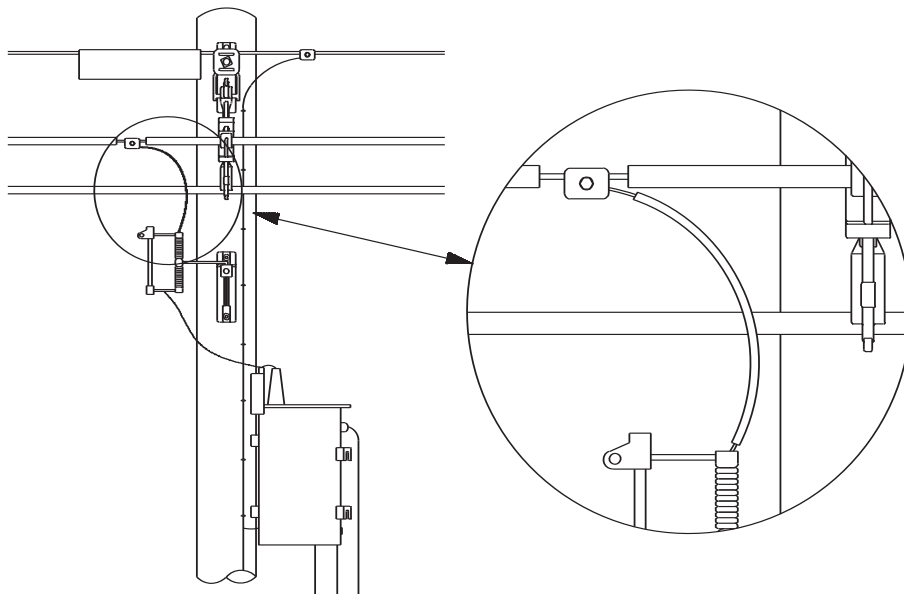

Part Number	Size	Strands	Conductor Diameter (in)	Conductor Thickness (in)	Overall Diameter (in)	Weight (lbs/ft)	Normal Ampacity with Sun/Wind* (amps)
TAP06CUSOL	#6 AWG	Solid	0.162	0.150	0.462	0.143	162
TAP06CUSTR	#6 AWG	7	0.178	0.150	0.478	0.145	162
TAP04CUSOL	#4 AWG	Solid	0.204	0.150	0.504	0.212	209
TAP04CUSTR	#4 AWG	7	0.232	0.150	0.532	0.214	209
TAP02CUSTR	#2 AWG	7	0.283	0.150	0.583	0.290	281
TAP10CUSTR	1/0 AWG	19	0.362	0.150	0.662	0.428	372
TAP40CUSTR	4/0 AWG	19	0.512	0.150	0.812	0.783	569

*105°C Conductor temperature; 25°C Ambient Temperature; Sun; 2ft./sec Wind

Description:

Hendrix insulated ground wire consists of a copper conductor, an inner layer of unfilled high molecular weight polyethylene and an outer layer of proprietary black, track and ultraviolet resistant, high density polyethylene.

Benefits:

- Eliminates expensive “outriggers” required by bare grounds
- Provides a neater pole
- Makes pole climbing and maintenance easier
- Available with pre-stripped ends to facilitate rapid installation

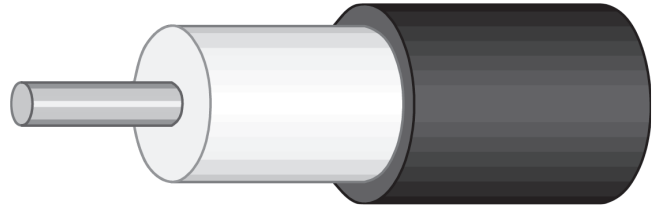

Application:

Hendrix insulated ground wire is used on wood pole transmission lines where a bare ground wire has insufficient BIL to meet system requirements. The insulating covering on the ground wire provides impulse withstand sufficient to meet the BIL requirements when the ground wire is stapled to the pole. The ground wire should extend above and below the phase conductors as shown in the table below. Specify insulated length required plus one foot for stripping (see packaging note).

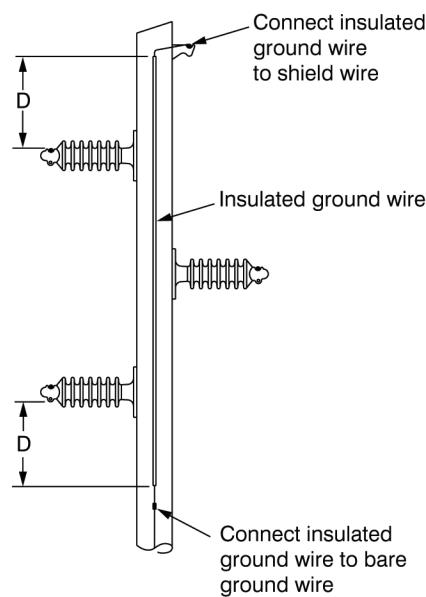

Packaging: Furnished in master reel quantities, straight lengths or coils with both ends stripped back 6.0” unless otherwise specified.

Catalog Number	System BIL (kV)	Conductor	Cable Diameter (in)	Insulation Thickness, Inner (in)	Insulation Thickness, Outer (in)	Weight (lb/ft)	Minimum Insulation distance “D” above top and below bottom phases (in)	Average impulse withstand strength (kV)
GW04CU350	350	#4 AWG Solid Copper	.804	0.150	0.150	0.322	36	450

Description:

The RTL Spacers are designed for use in the Hendrix Spacer Cable System. After being installed and clamped to the messenger, the spacers support, separate and clamp the phase conductors in a triangular configuration. The spacers are molded using a proprietary, gray, track resistant, UV resistant, high density polyethylene.

Benefits:

- Quick, easy installation and removal. Integral clamps for conductors and messenger, no ring ties required
- Clamp design accommodates full range of conductor and messenger sizes
- Wedge-shaped messenger hook provides maximum grip
- Optimum dielectric compatibility with Hendrix Spacer Cable
- Excellent weather washing characteristics
- Long leakage distance resists flashovers
- Close phase spacing minimizes voltage drop
- Unique design provides high short circuit strength
- Highly resistant to shock/impact/rifle fire
- Open diamond design provides neat appearance
- Can be installed with hot line tools

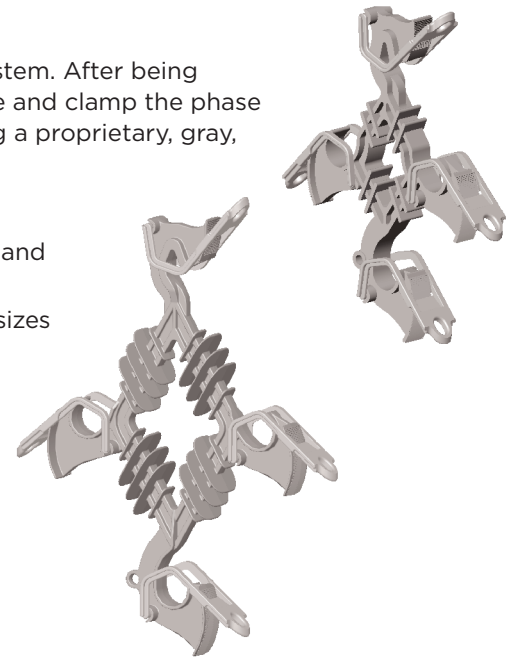

Application:

The RTL-15 is designed for use on distribution systems rated 5kV through 15kV. The RTL-46 is designed for use on distribution systems through 46kV. The RTL-GO95 can be used at any voltage through 46kV. It provides greater spacing for line crews that desire extra work area at tap locations or for applications where extra leakage distance is desired. It also meets the California and Hawaii GO95 spacing requirements for typical distribution system voltages. All spacer designs include a hole for attachment of a BAS AntiSway Bracket, if required, installation of the spacers should be made in accordance with Hendrix Installation Instructions. Spacers are installed at 30 foot intervals. For steep grade applications (greater than 20 degrees), specify the RTL-15DM or RTL-46DM or the RTL-GO95DM which is equipped with a metal clamp for fastening to the messenger. The clamp has a swivel which allows the spacer to hang vertically from the angled messenger.

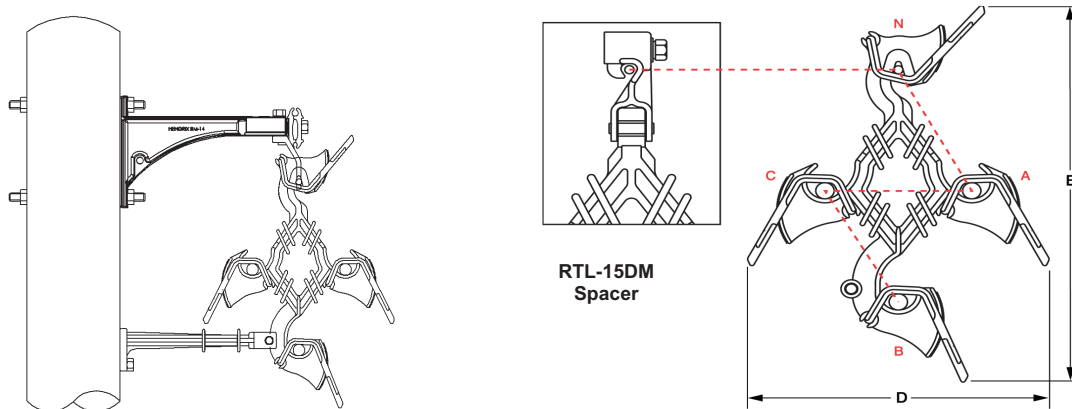

Part Number*	Dimensions (in)		Conductor Spacing (in)			Min. Leakage Distance (in)	Messenger Range (in)	Cable Range (in)	Max. System Voltage (kV)	Short Circuit Rating (kA)	Weight (lbs)
	D	E	AN	AC	BC						
RTL-15	16.5	23.5	8.5	8	8	10.75	.375 - .750	.438 - 2.00	15	13.5	2.5
RTL-46	20.5	29	12	11.5	11.5	17.5	.375 - .750	.438 - 2.00	46	16**	3.8
RTL-GO95	27.125	39.25	18	18	18	28.5	.375 - .750	.438 - 2.00	46	20**	5.5

*Specify RTL-15DM, RTL-46DM or RTL-GO95DM Spacer for steep grade or angle applications (greater than 20°)

**Calculated value

RTL-20V, RTL-20VXL Spacers



Description:

Designed for 20kV (phase-ground) distribution voltage, the RTL-20VXL is a single phase spacer used in Hendrix Spacer Cable Systems. The RTL-20VXL meets General Order 95 spacing requirements for system voltages up to and including 35kV. Mounted on a messenger wire, the RTL-20VXL will support the phase conductor in a vertical configuration. This spacer features ratcheting clamps to secure the messenger and conductor. Hendrix spacers are molded using a proprietary gray track resistant and UV resistant high density polyethylene material.

Benefits:

- Designed for easy and efficient installation and replacement
- Increased phase spacing for additional leakage distance requirements
- Integral ratcheting clamps secure our full range of messenger and phase conductor sizes
- Wedge-shaped messenger hook provides maximum grip
- Optimum dielectric compatibility with Hendrix Spacer Cable
- Excellent weather washing characteristics
- Long leakage distance resists flashovers
- Highly resistant to shock/impact/rifle fire
- Lightweight, rugged construction
- Can be installed with hot line tools

Application:

Use the RTL-20VXL in single phase distribution circuits rated up to 20kV, phase to ground. Typical application for the RTL-20VXL is backlot, residential construction. Installation of the spacers should be made in accordance with the appropriate Hendrix Aerial Cable System Instructions. Mount spacers at 30 foot intervals. Fasten to the messenger and conductor with the ratcheting clamps.

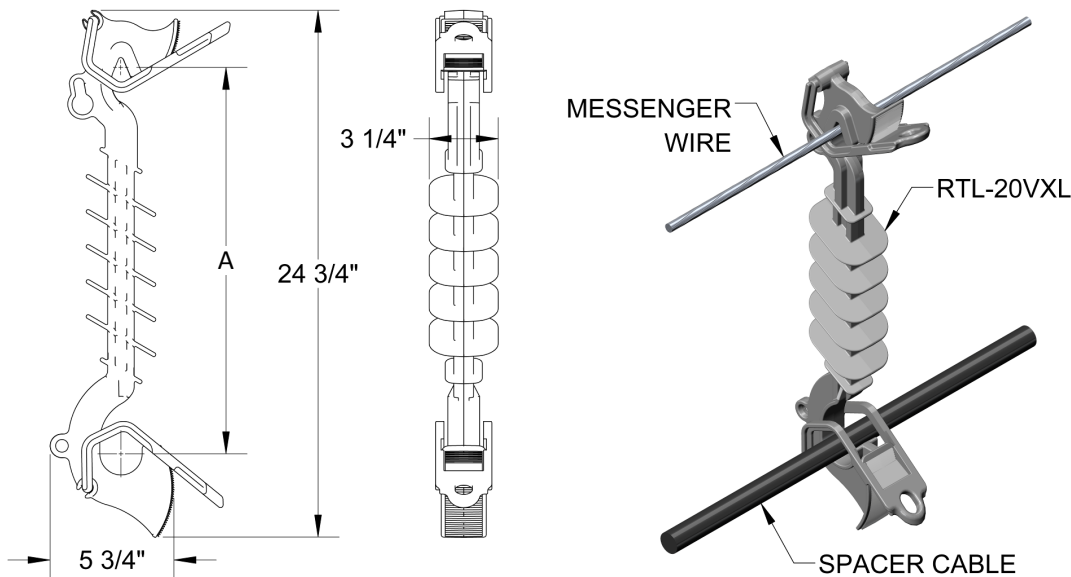
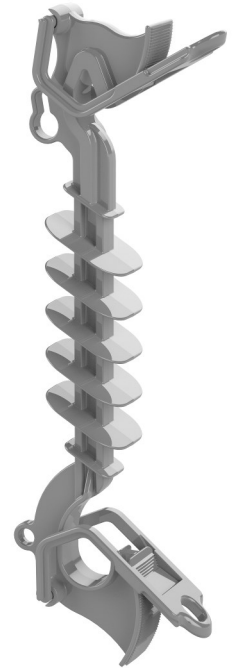

Part Number*	Overall Dimensions (in)				Min. Leakage Distance (in)	Max. Messenger Size (in)	Max. System Voltage (kV)	Max. Conductor Size (in)	Weight (lbs)
	Height	Width	Depth	A					
RTL-20V	17.75	3.25	5.75	12	20.5	3/4	35	2	1.50
RTL-20VXL	24.75	3.25	5.75	18.25	30.5	3/4	35	2	1.79

*Specify RTL-20VDM Spacer for steep grade or angle applications (greater than 20°)

Description:

Designed for 69kV transmission voltage, the RTL-69DM-01 is a three phase spacer used in Hendrix Spacer Cable Systems. Mounted on a messenger wire, the RTL-69DM-01 will support and separate the messenger and phase conductors in a diamond configuration. The RTL-69DM-01 includes a metal suspension clamp that fastens on the messenger and is a pivot point to hang a spacer vertically. The RTL-69DM-01 uses ratcheting clamps to secure the conductor. Hendrix spacers are molded using a proprietary gray track resistant and UV resistant high density polyethylene material

Benefits:

- Provides high strength and flexibility under dynamic loading
- Integral ratcheting clamps secure our full range of phase conductor sizes
- Metal clamp for secure fastening to the messenger
- Optimum dielectric compatibility with Hendrix Spacer Cable
- Excellent weather washing characteristics
- Long leakage distance resists flashovers
- Compact phase spacing minimizes voltage drop
- Highly resistant to shock/impact/rifle fire

Application:

Use the RTL-69DM in three phase transmission systems rated up to and including 69kV, phase to phase. Mount spacers at 30 foot intervals. The spacer is secured to the messenger by tightening the metal suspension clamp bolt. Fasten the conductors with the ratcheting clamps.

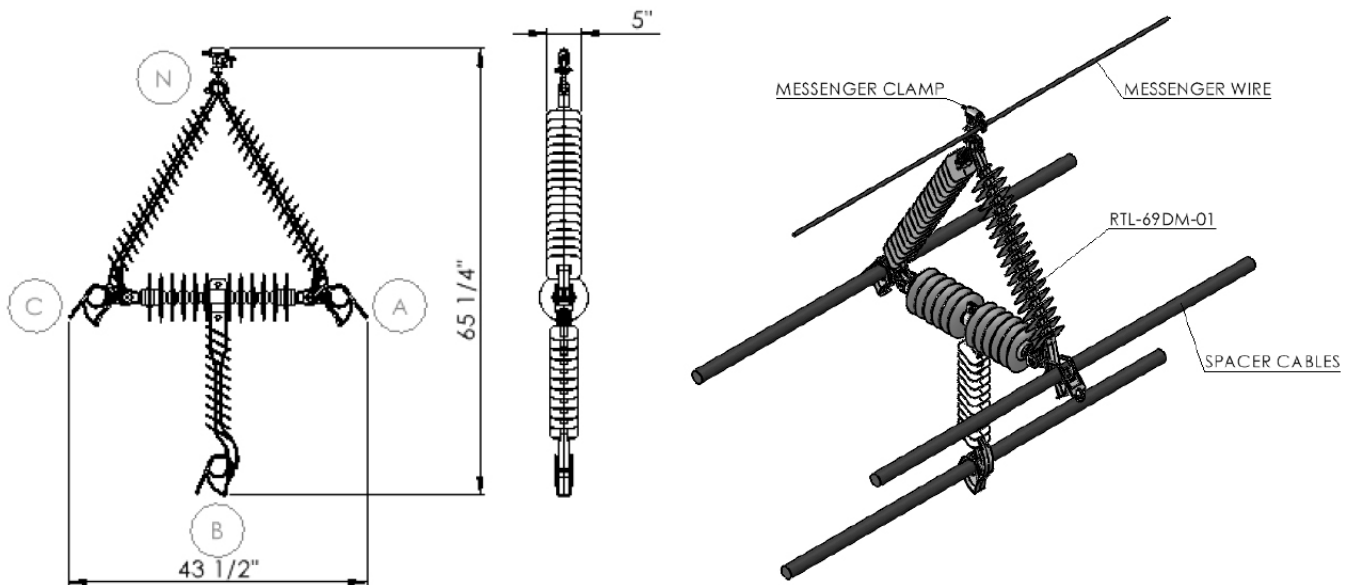
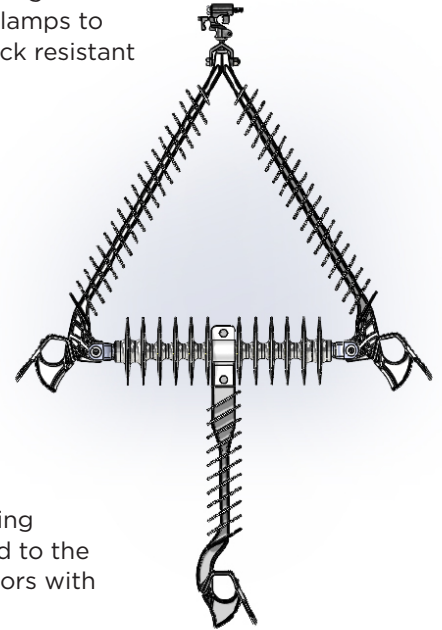

Part Number	Overall Dimensions (in)			Phase Spacing (in)				Minimum Leakage Distance (in)	Max. Messenger Size (in)	Max. System Voltage (Kv)	Short Circuit Rating (kA)	Weight (lbs)
	Height	Width	Depth	AN	AC	BC	BN					
RTL-69DM-01	65.25	43.5	5	36.25	34.25	30	56.25	80	1.0	69	30*	21.4

*Calculated value

Description:

Designed for 115kV transmission voltage, the RTL-115 is a three phase spacer used in Hendrix Spacer Cable Systems. Mounted on a messenger wire, the RTL-115 will support and separate the messenger and phase cables. The RTL-115 includes a metal suspension clamp that fastens on the messenger and is a pivot point to allow the spacer to hang vertically. RTL-115 uses clamps with thermoplastic inserts to secure the conductor. Hendrix spacer insulators are molded using a proprietary gray track resistant and UV resistant high density polyethylene material.

Benefits:

- Provides high strength and flexibility under dynamic loading.
- Metal clamp for secure fastening to the messenger.
- Polyethylene cable clamp inserts for Optimum dielectric compatibility with Hendrix Spacer Cable.
- Excellent weather washing characteristics.
- Long leakage distance resists flashovers.
- Highly resistant to shock/impact/rifle fire.
- Multiple pivot points alleviate system mechanical stress.

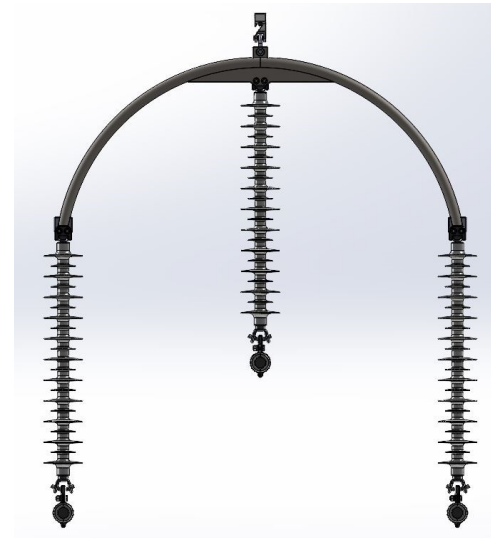

Application:

Use the RTL-115 in three phase transmission systems rated up to and including 115kV, phase to phase. Mount spacers at 50 foot intervals. The spacer is secured to the messenger by tightening the metal suspension clamp bolt. Fasten the conductors with the clamps. The cable clamp inserts vary with cable size to provide secure connection and reduce stresses.

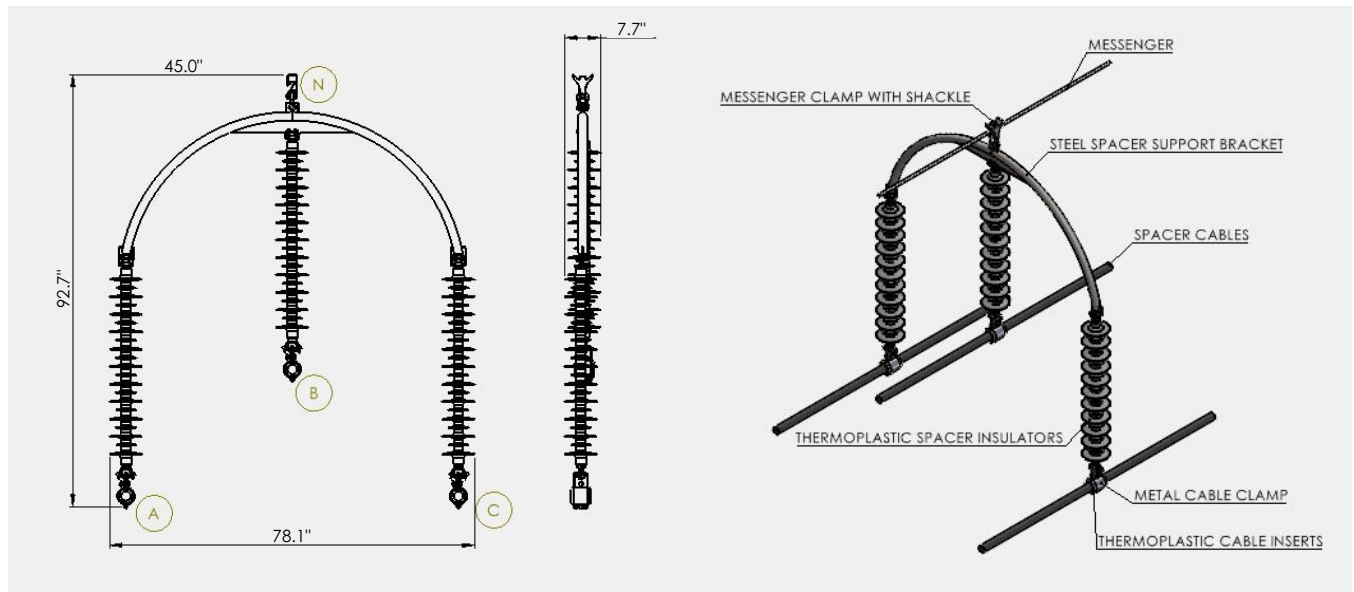

Part Number	Overall Dimensions (in)			Phase Spacing (in)				Minimum Leakage Distance (in)	Max. Messenger Size (in)	Critical Impulse Flashover (kV)*		Power Frequency Flashover (kV)*		Weight (lbs)
	Height	Width	Depth	AB	AC	AN	BN			Positive	Negative	Dry	Wet	
RTL-115-XXX**	92.7	78.1	7.7	45	71.3	88	64.5	109	1	763	753	468	407	87

*All testing performed line to ground on a spacer insulator with bare wire

**Part number size is the suffix. Example: RTL-115-336 for 336KCM AAC

BM-14, BM-24 Tangent Brackets



Description:

The BM-14 and BM-24 are tangent brackets designed specifically for use with Hendrix Spacer Cable Systems. All tangent brackets are supplied with a Hendrix MC-2 messenger clamp. Brackets are cast ductile iron that is hot dip galvanized after fabrication.

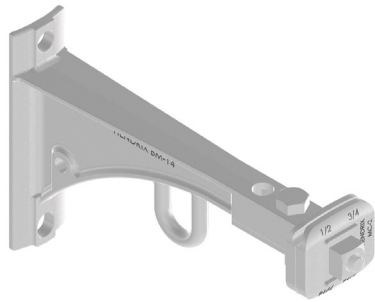

BM-14

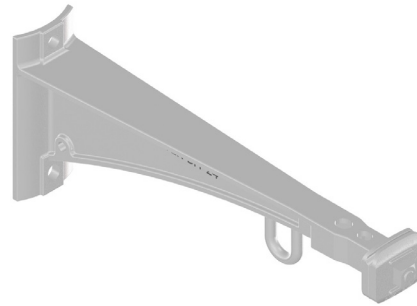

BM-24

Benefits:

- Designed to work in conjunction with Hendrix Roll-By installation equipment and allow continuous, uninterrupted pulling past tangent structures.
- Tangent brackets are designed fore “back to back” double circuit construction.
- Tangent brackets will accept a standard short shank insulator pin (up to 3/4” shank diameter) and insulator for single phase spacer cable angle construction as well as “armless” tree wire construction

Application:

BM brackets are designed to support the spacer cable messenger wire. They are used on tangent poles and line angles up to 6°. Pole mounting is accomplished using either 5/8” or 3/4” thru-bolts (not included).

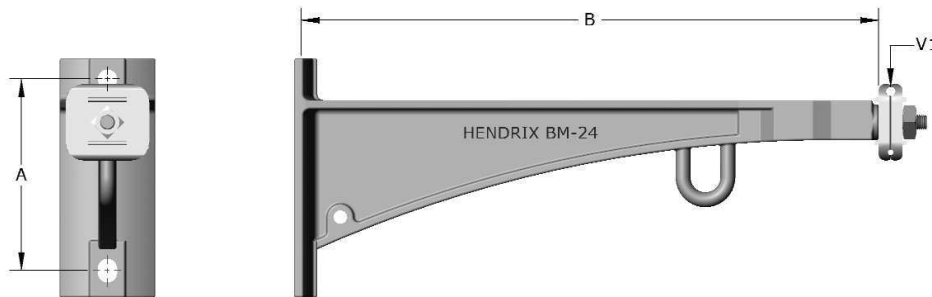

Mounting tangent brackets to flat surfaces shall be assembled with aluminum shim plates. Contact Hendrix for further assistance.

Part Number	System Voltage	Dimensions (in)		Min. Ultimate Load (lbs) V1 (vertical)	Weight (lbs)	Material
		A	B			
BM-14	15kV and below	8	14	3,200	8.6	HDG Ductile Iron
BM-24	46kV and below	8	24	6,000	19	HDG Ductile Iron

BAS-14F, BAS-14S, BAS-24F Anti-Sway Brackets



Description:

The BAS-14F, BAS-14S and BAS-24F Anti-Sway Brackets are designed to be used on tangent Hendrix Spacer Cable structures. These brackets are injection molded, proprietary, high density polyethylene. All anti-sway brackets are supplied with a molded clevis pin for attachment to the spacer.

Benefits:

- Stabilizes the spacer at transformer tap poles and eliminates flexing of the transformer lead wire and stress on connections due to movement of the Hendrix Spacer Cable System
- Helps minimize excessive swinging of the Spacer Cable System in high wind areas

Application:

Anti-sway brackets should be used when there is a tap connection to stabilize spacers on tangent poles and line angles up to 6° and can be used with any Hendrix spacer. The BAS-24F is designed with extra leakage distance for contaminated areas. The BAS-14F and BAS-24F are mounted on the front of the pole, directly under the tangent bracket, and require a TS-1 stirrup to be used with the tangent bracket. The BAS-14S is mounted to the side of the pole and does not require the TS-1 stirrup. Pole mounting is accomplished using a 1/2" lag bolt (not included).

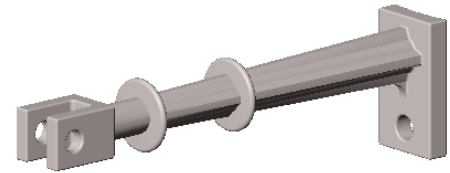

BAS-14F

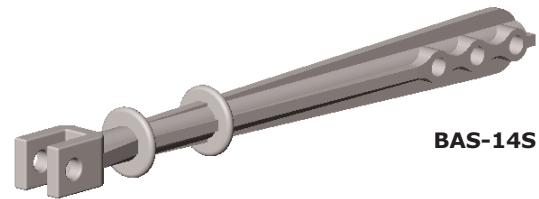

BAS-14S

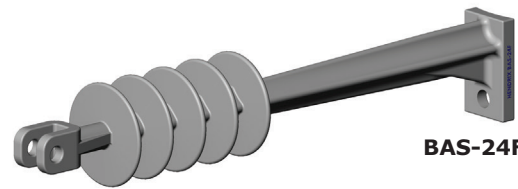

BAS-24F

Part Number	Compatible/Required Hardware		
	BM-14	BM-24	TS-1
BAS-14F	X	—	X
BAS-14S	X	—	—
BAS-24F	—	X	X

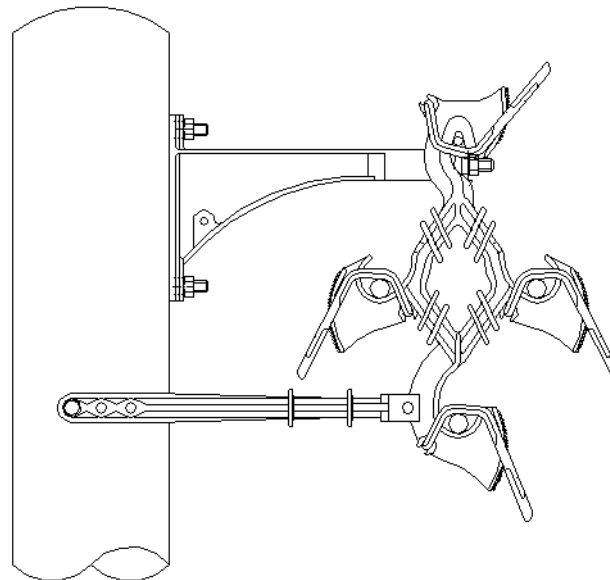
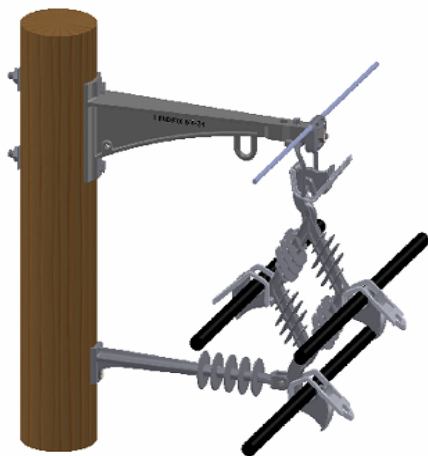

continued

BAS-14F, BAS-14S, BAS-24F Anti-Sway Brackets



BAS-14F

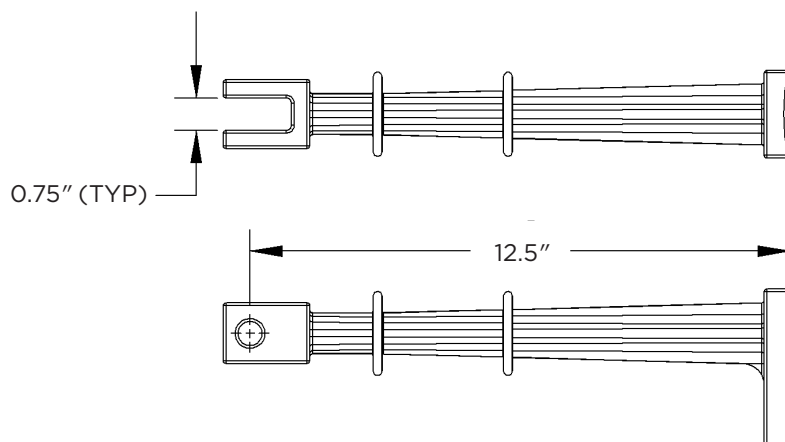

BAS-14S

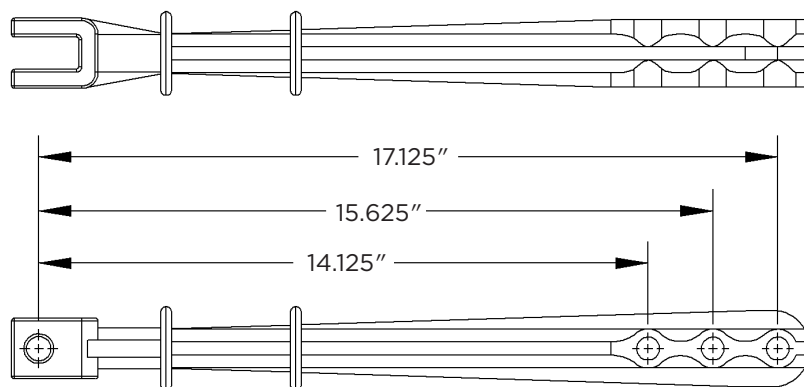

BAS-24F

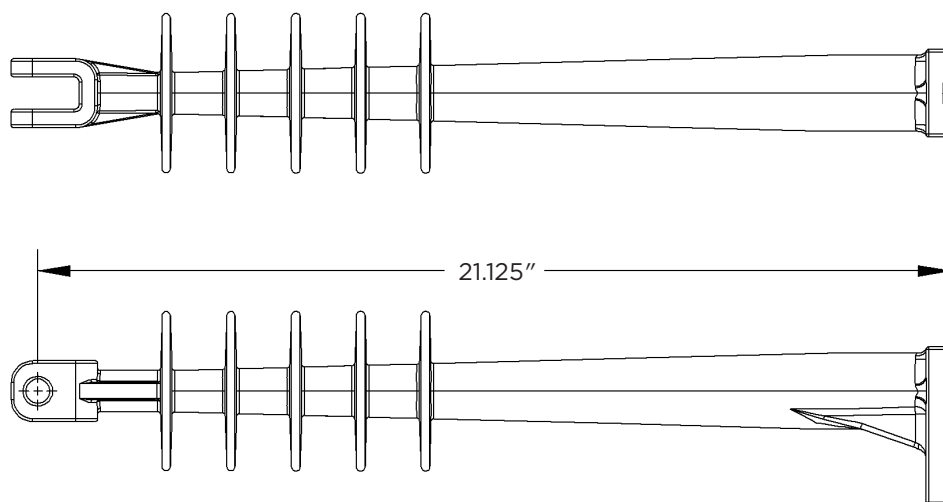

TS-1 Tangent Bracket Stirrup MC-2 Messenger Clamp



Description:

The TS-1 Tangent Bracket Stirrup is an accessory that is used to support a spacer directly beneath a tangent bracket in Hendrix Spacer Cable Systems. The stirrup is cast ductile iron that is hot dip galvanized after fabrication.

Benefit:

When used in conjunction with the Hendrix BAS-14F or BAS-24F anti-sway bracket, the stirrup helps eliminate undesirable movement of the spacer cable system at transformer tap poles.

Application:

The TS-1 stirrup can be used with any Hendrix tangent bracket. The stirrup should be attached to the tangent bracket using the hole closest to the end of the tangent bracket using the hardware that is supplied with the TS-1. If the Roll-By installation method is used, the TS-1 stirrup should be attached as the spacers are being installed.

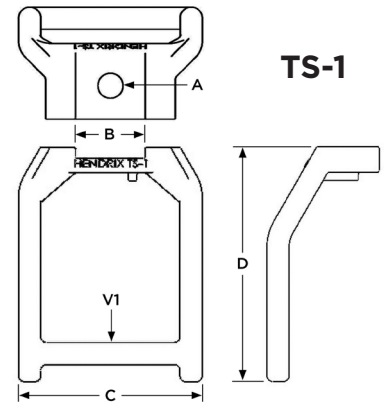
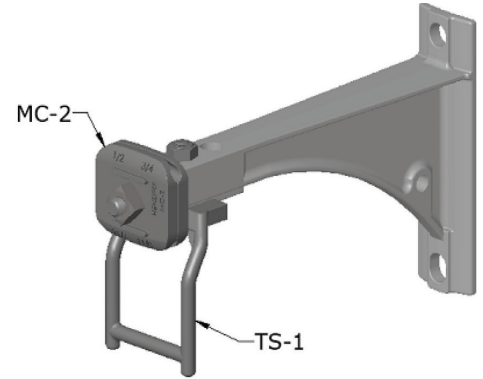

MC-2 Messenger Clamp

Description:

The MC-2 Messenger Clamp is used on tangent brackets in Hendrix Spacer Cable Systems. The clamp is cast ductile iron and is hot dip galvanized after fabrication.

Benefits:

- Allows the PBR-3 roll-by blocks and TM messenger trolley to roll over the tangent brackets for smooth, uninterrupted installation of the Spacer Cable System
- Two clamping grooves allow use with a broad range of messenger sizes

Application:

The MC-2 messenger clamp and mounting hardware are supplied with each tangent bracket. Each casting is marked with the size range for the two clamping grooves. The appropriate groove should be used for the messenger selected to ensure that adequate clamping force is maintained.

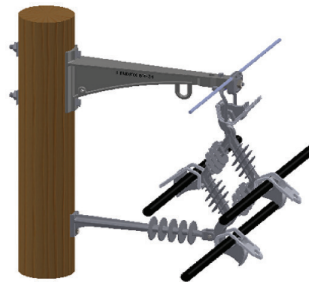
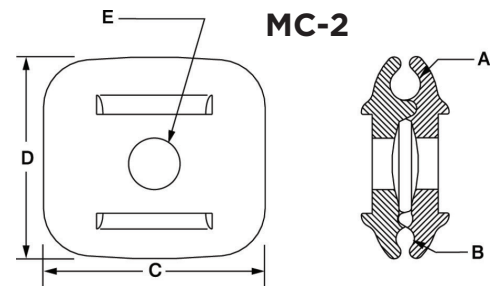

Part Number	Dimensions (in)					Min. Ultimate Load (lbs) V1	Weight (lbs)	Material
	A	B	C	D	E			
TS-1	$\frac{5}{16}$	$1 \frac{1}{16}$	3.5	4.5	—	3,100	.78	HDG Ductile Iron
MC-2	$\frac{1}{2} - \frac{3}{4}$	$\frac{5}{16} - \frac{7}{16}$	3.5	3.1875	$\frac{13}{16}$	—	2.2	HDG Ductile Iron

MC-4 Messenger Clamp



Description:

The MC-4 Messenger Clamp is used on davit arms in Hendrix Spacer Cable Systems for situations when the loading from spacer cable spans are too great for the BM-24. The clamp is cast ductile iron and is hot dip galvanized after fabrication.

Benefits:

- Allows the PBR-3 roll-by blocks and TM messenger trolley to roll over the davit arms for a smooth, uninterrupted installation of the Spacer Cable System
- The clamping groove allows use with a broad range of messenger sizes.

Application:

The MC-4 messenger clamp and mounting hardware are supplied to mount on a davit arm. Also, Hendrix engineering provides a drawing to the customer of an end plate adapter that must be fabricated on the end of each davit for the MC-4 parts to be able to fit. The drawing is available on our website.

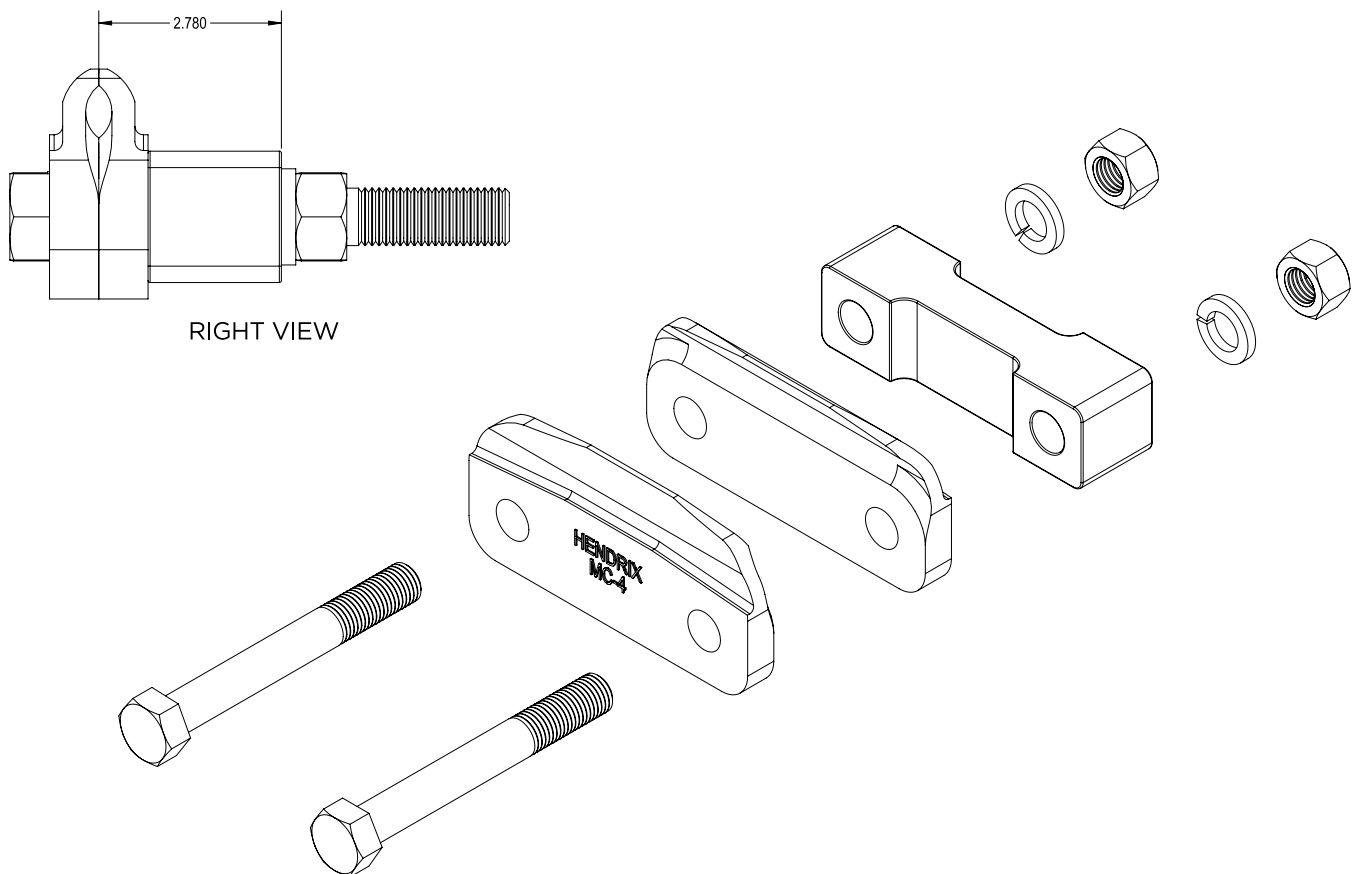
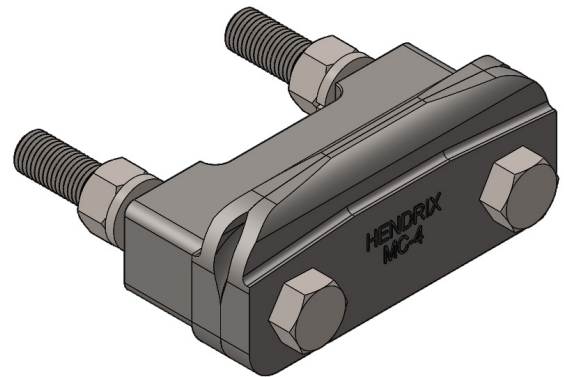

BA3-15, BA3-35 Angle Brackets



Description:

The BA3-15 and BA3-35 are angle brackets used with Hendrix Spacer Cable Systems. The brackets are formed using 3.0" channel and are hot dip galvanized after fabrication. The BA3-35 includes welded gussets for maximum strength.

Benefits:

- Maintains the triangular configuration of the phase conductors.
- Simple, compact alternative to crossarm angle construction
- 8.0" mounting hole spacing conforms to standard pre-drilled poles for ease of installation
- Ground Lug Provision

Application:

Pole mounting is accomplished using thru-bolts (not included).

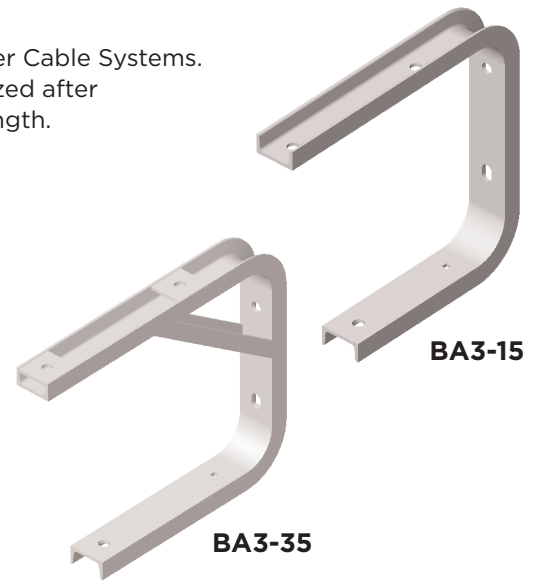

Part Number	System Voltage	Line Angle	Conductor Size	Insulator(s)	Insulator Pin Length (in)	2IP Insulator Plate
BA3-15	15kV	7° - 60° 61° - 90°	All All	HPI-15, HPI-15VT HPI-15, HPI-15VT	7 7	Not Required Required
BA3-35	25kV	7° - 44°	All	HPI-25, HPI-25VT	7	Not Required
		45° - 60°	Below 336.4	HPI-25, HPI-25VT	7	Not Required
		45° - 60° 61° - 90°	336.4 and larger All	HPI-25, HPI-25VT HPI-25, HPI-25VT	7 7	Required Required
35kV	7° - 44°	All	HPI-35, HPI-35VT	7	Not Required	
	45° - 60°	Below 336.4	HPI-35, HPI-35VT	7	Not Required	
	45° - 60° 61° - 90°	336.4 and larger All	HPI-35, HPI-35VT HPI-35, HPI-35VT	7 7	Required Required	

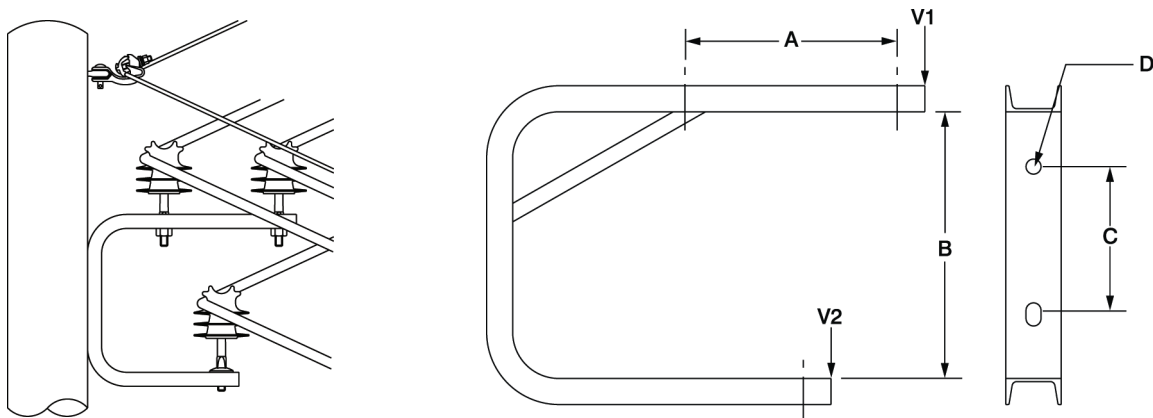

Part Number	System Voltage	Dimensions (in)				Min. Yield Load (lbs)		Weight (lbs)	Material
		A	B	C	D	V1	V2		
BA3-15	15kV and below	11.5	16.5	8	13/16	950	1,200	19.4	HDG ASTM A-36 Structural Steel
BA3-35	46kV and below	13.5	16.5	8	13/16	1,700	1,000	28.0	HDG ASTM A-36 Structural Steel

BA4-15, BA4-35 Angle Bracket



Description:

The BA4-15 and BA4-35 are angle brackets used with Hendrix Spacer Cable Systems. The bracket is formed C3x4.1 ASTM A-36 and hot dip galvanized after fabrication.

Benefits:

- Top arm of bracket accepts Hendrix CMA-1 or CMA-2 (with UB, "U" bolt) messenger angle clamps, reducing the number of hardware items to complete the angle construction
- Maintains the diamond configuration of the messenger and phase conductors which improves the shielding of the system compared to the pole mounted messenger clamp
- Ground Lug Provision

Application:

The BA4-15 and BA4-35 angle brackets are used on structures where the line angle does not exceed 60°. This bracket is designed to be used with Hendrix Tie Top polyethylene insulators and covered tie wire, or Vise-Top polyethylene insulators. Angle brackets are mounted to poles using thru-bolts (not included).

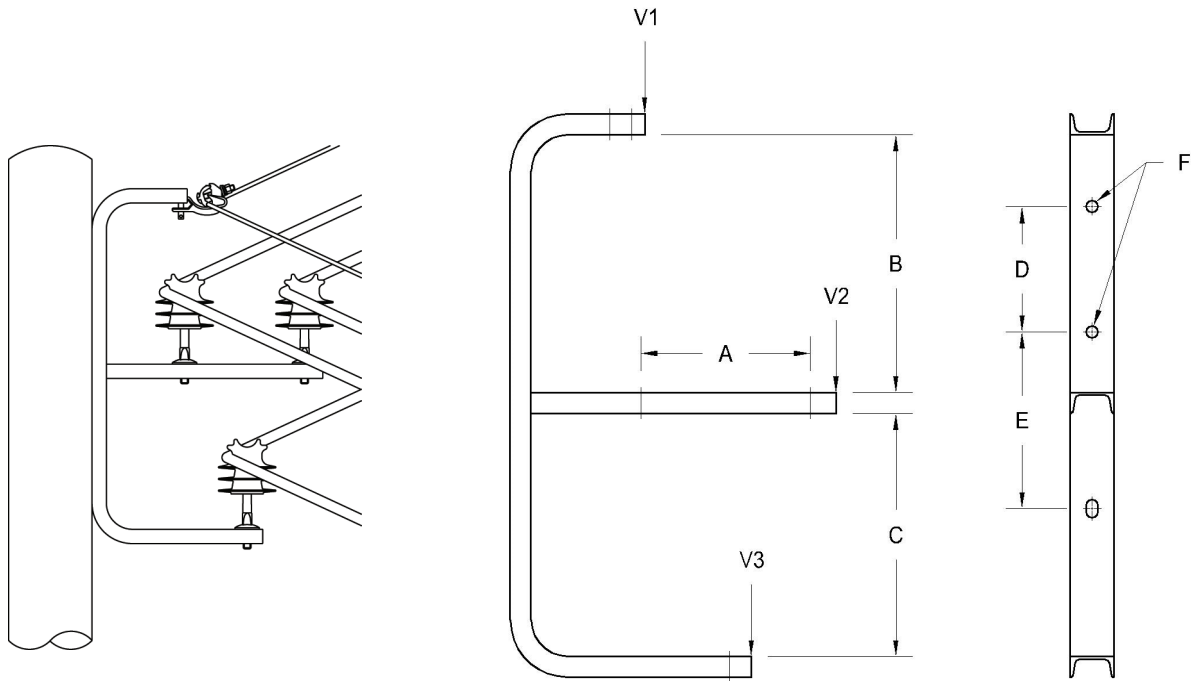

Part Number	System Voltage	Dimensions (in)						Min. Yield Load (lbs)		Weight (lbs)	Material
		A	B	C	D	E	F	V1	V2		
BA4-15	15kV and below	11.5	17.5	16.5	8.5	12	13/16	1,200	1,000	27	HDG ASTM A-36 Structural Steel
BA4-35	25kV to 46kV	13.5	19.3125	18.5	8.5	18.375	13/16	1,700	1,000	34	HDG ASTM A-36 Structural Steel

BA6-15 Angle Bracket



Description:

The BA6-15 is a double circuit angle bracket used with Hendrix Spacer Cable Systems. The bracket is formed using 3.0" channel and includes welded gussets for maximum strength. The bracket is hot dip galvanized after fabrication.

Benefits:

- Maintains close spacing of conductors
- Space saving alternative to using two single circuit brackets
- Ground Lug Provision

Application:

The BA6-15 may be used on voltages through 35kV. This bracket is designed to be used with Hendrix Tie Top polyethylene insulators and covered tie wire, or Vise-Top polyethylene insulators with 2IP plate, if required. The messenger mounting hole can be used in conjunction with CMA-1 or CMA-2 messenger clamps on angles from 7° - 60°. Pole mounting is accomplished using thru-bolts (not included).

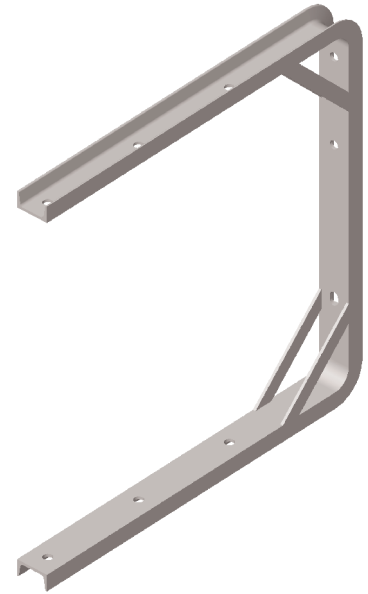

Part Number	System Voltage	Line Angle	Conductor Size Limitation	2IP Insulator Plate Requirement
BA6-15	15kV	7° - 60°	All	Not Required
		61° - 90°	BA6-15 not recommended	
	25kV	7° - 44°	All	Not Required
		45° - 60°	≥ 336kcm	Required
		61° - 90°	BA6-15 not recommended	
	35kV	7° - 44°	All	Not Required
		45° - 60°	≥ 336kcm	Required
		61° - 90°	BA6-15 not recommended	

Note: For line angles >60°, Hendrix recommends using two BA3-15 or BA3-35 brackets.

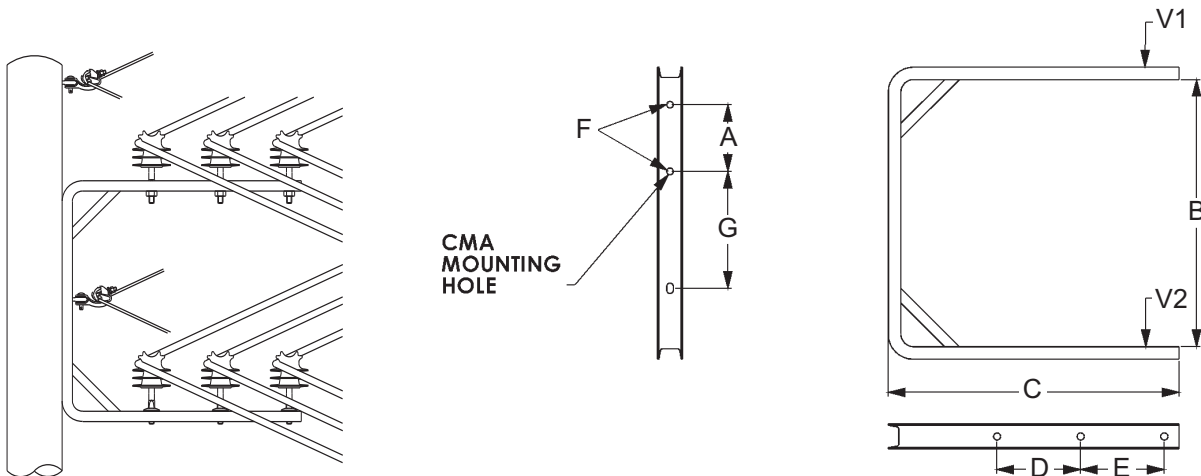

Part Number	System Voltage	Dimensions (in)							Min. Yield Load (lbs)		Weight (lbs)	Material
		A	B	C	D	E	F	G	V1	V2		
BA6-15	35kV and below	8	32	34.75	10	10	13/16	14	900	900	42.0	HDG ASTM A-36 Structural Steel

BA6-15-25C Horizontal Bracket



Description:

The BA6-15-25C is a three phase bracket used to maintain a horizontal configuration of the conductors. The bracket is formed using 3.0" channel and is hot dip galvanized after fabrication. The welded gussets provide added strength to support larger size conductors.



Benefits:

- The horizontal configuration makes multi-phase connections more convenient.
- Large phase spacing makes it easier to strip conductors for tap connections.
- Allows for "flying tap" connections between two crossing circuits.
- Ground Lug Provision

Application:

The BA6-15-25C may be used on circuits up to 35 kV. It is intended to be used at tangent or angle poles where there are tap connections. This bracket is designed to be used with Hendrix Tie Top polyethylene insulators and covered tie wire, or Vise-Top polyethylene insulators. Pole mounting is accomplished using thru-bolts (not included).

Part Number	System Voltage	Line Angle	Conductor Size	2IP Insulator Plate
BA6-15-25C	15kV	7° - 60°	All	Not Required
		61° - 90°	≤ 556kcm	Required
	25kV	7° - 44°	All	Not Required
		45° - 60°	< 336.4kcm	Not Required
		45° - 60°	≥ 336.4kcm	Required
	35kV	61° - 90°	≤ 556kcm	Required
		7° - 44°	All	Not Required
		45° - 60°	< 336.4kcm	Not Required
		45° - 60°	≥ 336.4kcm	Required
61° - 90° BA6-15-25C not recommended				

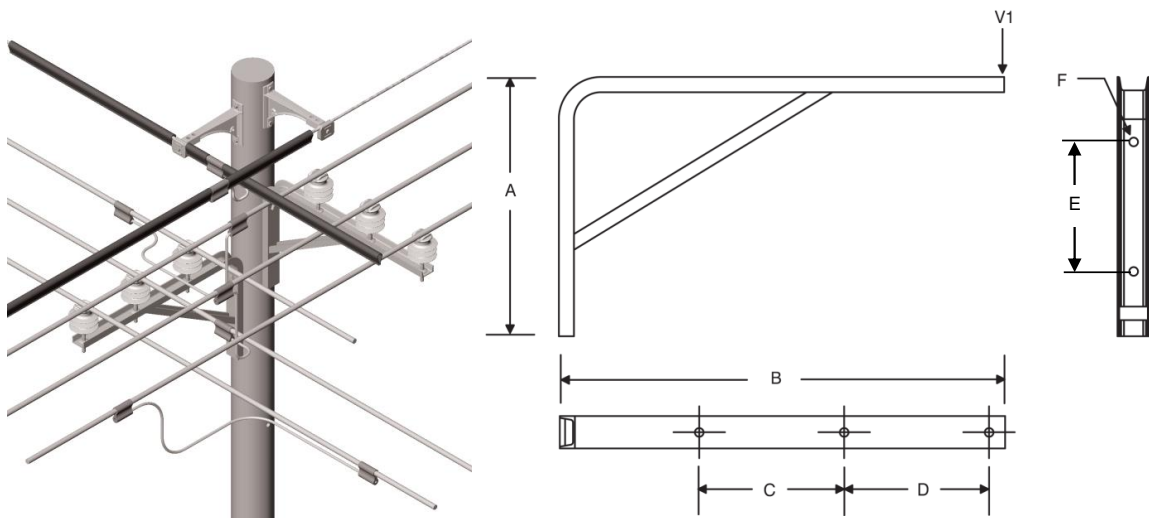

Part Number	System Voltage	Dimensions (in)						Min. Yield Load V1 (lbs)	Weight (lbs)	Material
		A	B	C	D	E	F			
BA6-15-25C	35kV and below	24	41.5	13.5	13.5	12	1 ³ / ₁₆	2,000	31.1	HDG ASTM A-36 Structural Steel

BA1-PP Pole Cornering Plate



Description:

- BA1-PP is a mounted bracket used to double dead-end spacer cable covered conductors
- Bracket is made of galvanized structural steel

Benefits:

- Allows Spacer Cable conductors to be dead-ended directly to the pole
- * Attaches to pole with one 3/4" machine bolt
- * Accepts Hendrix SSP-2 pin for horizontally mounted pin insulators for supporting jumper wire

Application:

- The BA1-PP can be used on line angles from 7 to 90 degrees
- * The BA1-PP may be used for systems from 5kV to 69kV

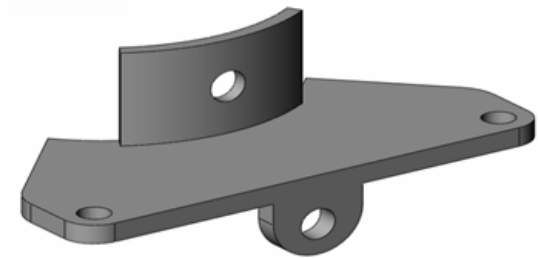

Dimensions:

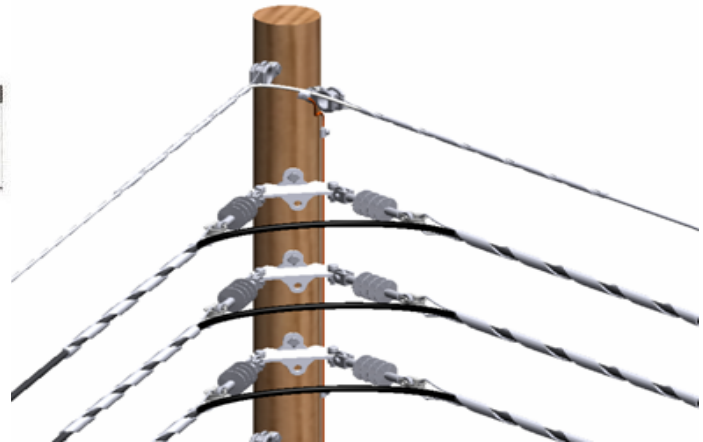
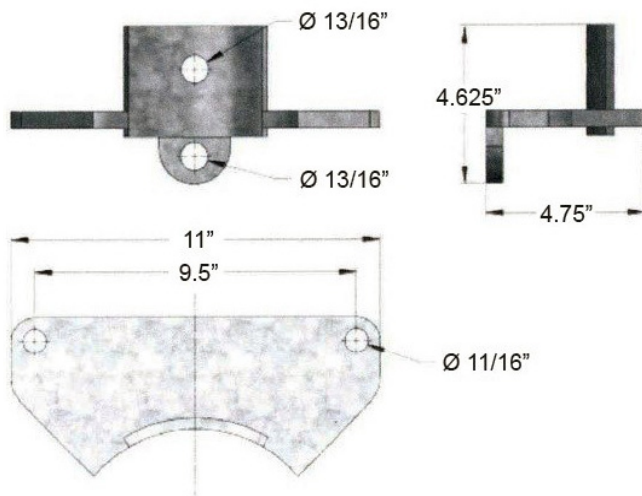

BD-35 Dead-end Bracket



Description:

The BD-35 is a dead-end bracket used with Hendrix Spacer Cable Systems. The bracket is formed using 3.0" channel and 2.0" structural angle and is hot dip galvanized after fabrication.

Benefits:

- Compact configuration of messenger and phase conductors is maintained, providing better shielding than crossarm dead-end construction
- Simplifies pole framing compared to crossarm dead-end construction
- 8.0" mounting hole spacing conforms to standard pre-drilled poles for ease of installation
- Ground Lug Provision

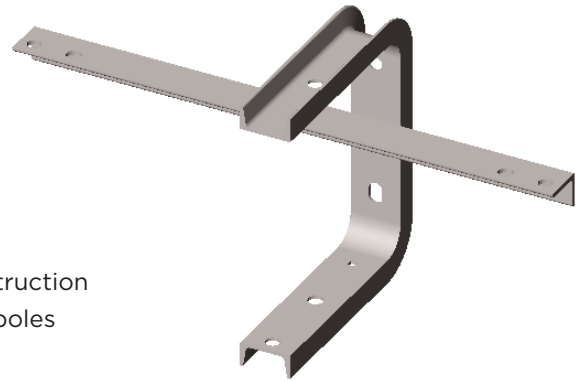

Application:

This bracket is recommended for use on circuit dead-ends as well as double dead-end angle construction. Where an insulator is required to support a jumper, Hendrix HPI insulators and covered tie wire or HPI Vise-Top insulators should be used. The messenger should be dead-ended on the pole above the bracket. Pole mounting is accomplished using thru-bolts (not included).

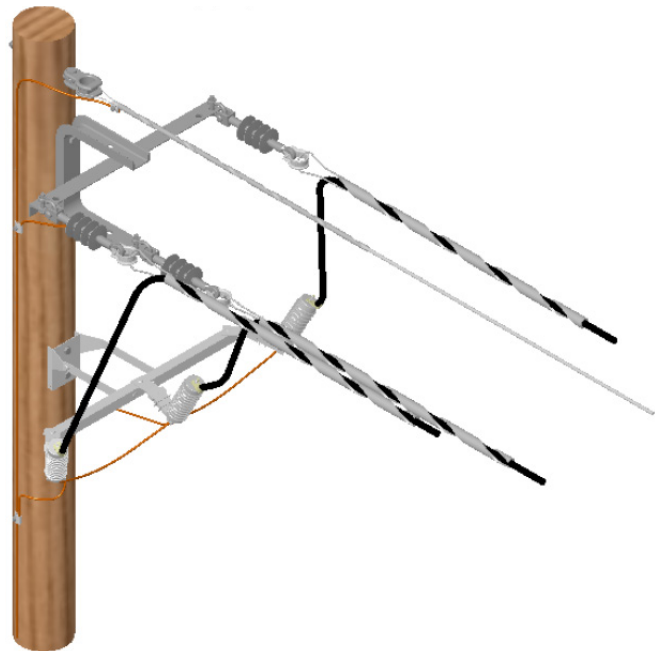
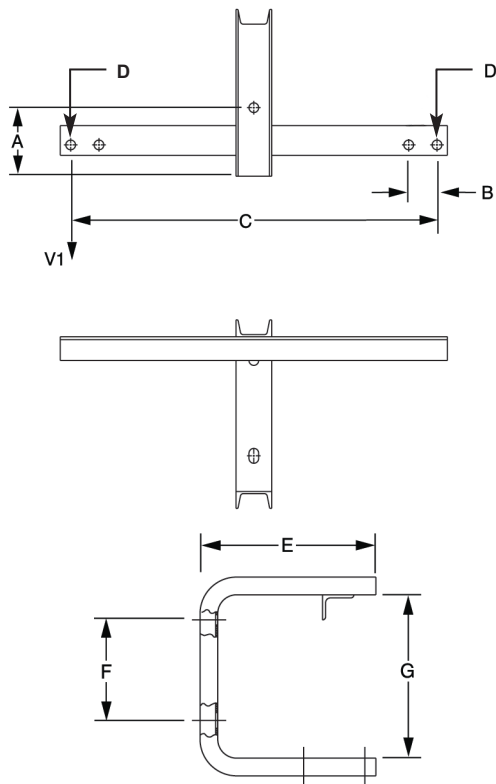

Part Number	Dimensions (in)							Min. Yield Load V1 (lbs)	Weight (lbs)	Material
	A	B	C	D	E	F	G			
BD-35	5.75	2.375	30.75	1 ³ / ₁₆	14	8	13.25	1,000	23.4	HDG ASTM A-36 Structural Steel

BV-35 Vertical Tap/Angle Bracket



Description:

The BV-35 is a vertical tap/angle bracket used with Hendrix Spacer Cable Systems. The bracket is formed using 3.0" channel and is hot dip galvanized after fabrication.

Benefits:

- The phase conductors are supported in a vertical orientation to permit taps to be made while still maintaining a compact configuration
- Simple, compact alternative to crossarm angle or tap construction
- Ground Lug Provision

Application:

The BV-35 is designed for primary lateral taps at all voltages through 35kV. These brackets can also be used on angles up to 90° in applications where a vertical configuration of the phase conductors is desired. This bracket is designed to be used with Hendrix Tie Top polyethylene insulators and covered tie wire, or Vise-Top polyethylene insulators with 2IP plate, if required. Pole mounting is accomplished using thru-bolts (not included).

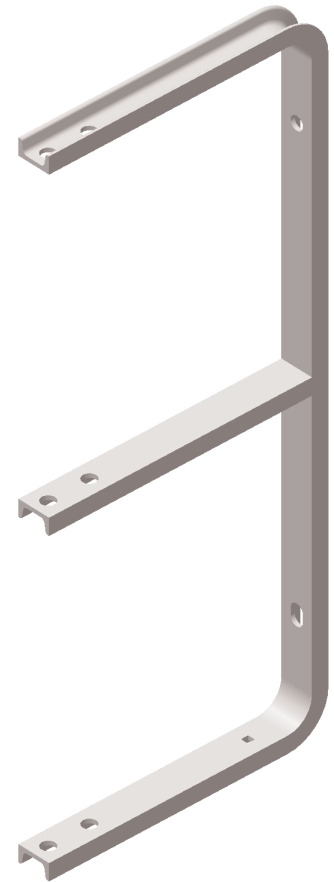

Part Number	System Voltage	Line Angle	Conductor Size	2IP Insulator Plate
BV-35	15kV	7° - 60°	All	Not Required
		61° - 90°	All	Required
	25/35kV	7° - 44°	All	Not Required
		45° - 60° 45° - 60° 61° - 90°	Below 336.4 336.4 and larger All	Not Required Required Required

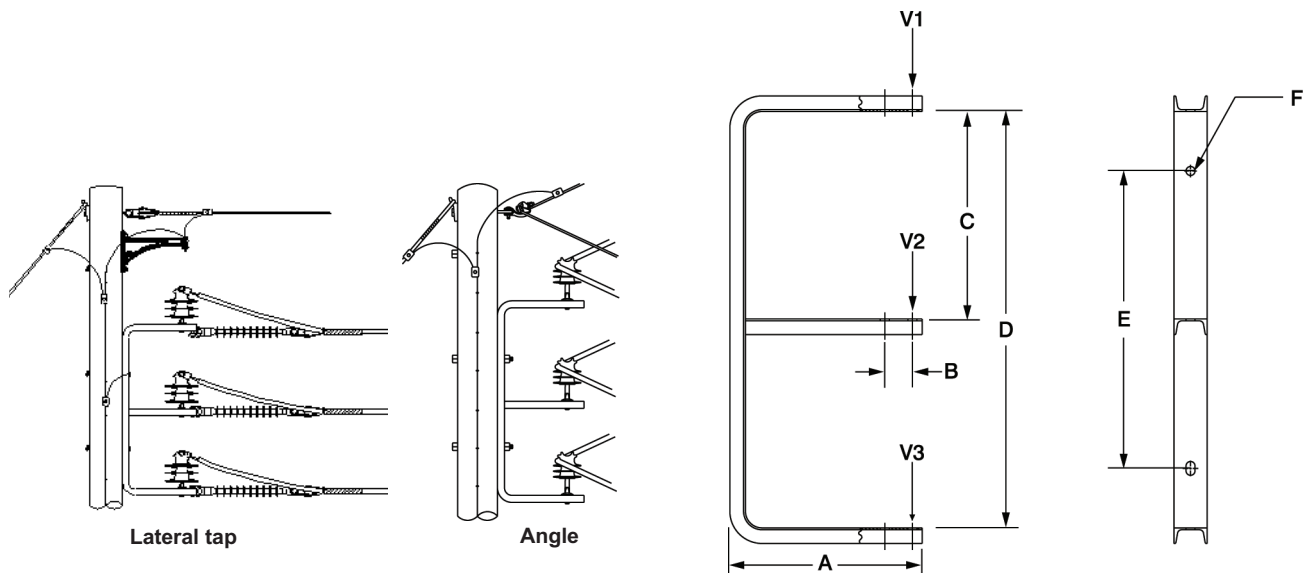

Part Number	Dimensions (in)						Min. Yield Load (lbs)			Weight (lbs)	Material
	A	B	C	D	E	F	V1	V2	V3		
BV-35	17.375	2.5	13.5	13.5	12	13/16	1,150	1,600	1,100	17.3	HDG ASTM A-36 Structural Steel

BT3-35 Transformer Tap Bracket



Description:

The BT3-35 is a transformer tap bracket used with Hendrix Spacer Cable Systems. The bracket is formed using 4.0" channel and includes welded gussets for maximum strength. The bracket is hot dip galvanized after fabrication.

Benefits:

- Increased phase separation provides more working clearance and facilitates stripping the phase conductors for tap connections
- Maintains the triangular configuration of the phase conductors
- Reduces movement of phase conductors due to wind thereby reducing the stress on transformer tap wires
- 8.0" mounting hole spacing conforms to standard pre-drilled poles for ease of installation
- Ground Lug Provision

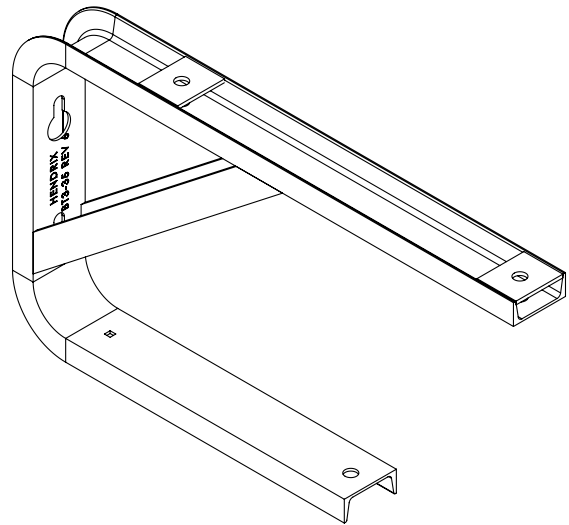

Application:

The BT3-35 tap bracket can be used on any structure where the line angle does not exceed 60° and increased phase separation is desirable (provides more spacing than the BA3-15 and BA3-35 brackets). This bracket is designed to be used with Hendrix Tie Top polyethylene insulators and covered tie wire, or Vise-Top polyethylene insulators. Pole mounting is accomplished using thru-bolts (not included).

Part Number	System Voltage	Line Angle	Conductor Size	2IP Insulator Plate
BT3-35	15kV	7° - 60°	All	Not Required
	35kV and below	7° - 44°	All	Not Required
		45° - 60° 45° - 60°	Below 336.4 336.4 and larger	Not Required Required

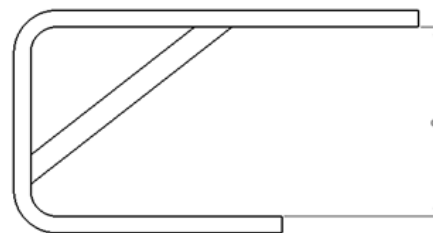
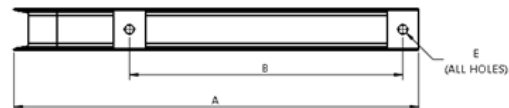
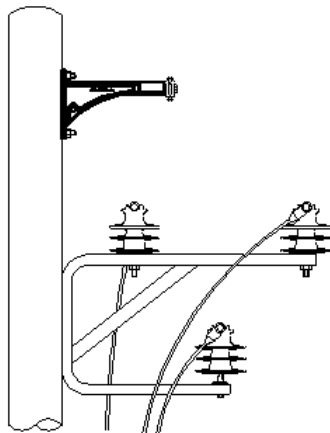

Part Number	System Voltage	Dimensions (in)					Weight (lbs)	Material
		A	B	C	D	E		
BT3-35	35kV and below	38.5	26	18	8	13/16	42	HDG ASTM A-36 Structural Steel

CMA-1, CMA-2 Angle Clamps, UB-HD U-Bolt



Description:

The CMA-1 and CMA-2 are messenger angle clamps used with Hendrix Spacer Cable Systems. The clamps are cast ductile iron which are hot dip galvanized after fabrication.

Benefits:

- A material and labor cost savings alternative to messenger dead-end construction on angles
- Designed to work with Hendrix angle brackets for efficient installation

Application:

The CMA-1 clamp is designed for angles that pull away from the pole. The clamp will attach directly to the Hendrix BA4-15 angle bracket. When other Hendrix angle brackets are specified, the CMA-1 should be installed using a thru eyebolt. The CMA-2 clamp is designed for angles that pull towards the pole. The clamp should be attached to the BA4-15 angle bracket using a "U" bolt Hendrix Catalog No. UB-HD.

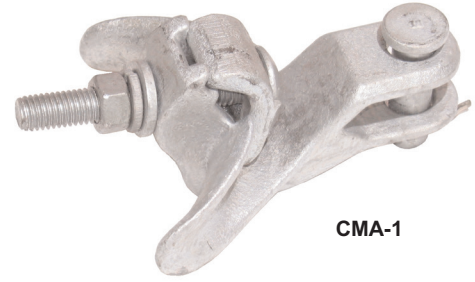

CMA-1

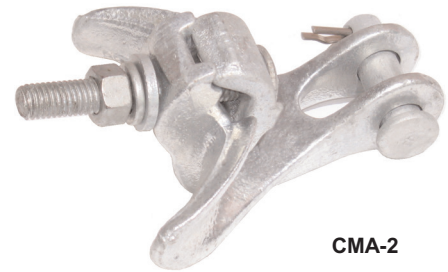

CMA-2



UB-HD

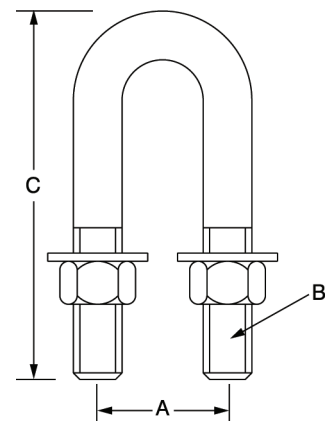
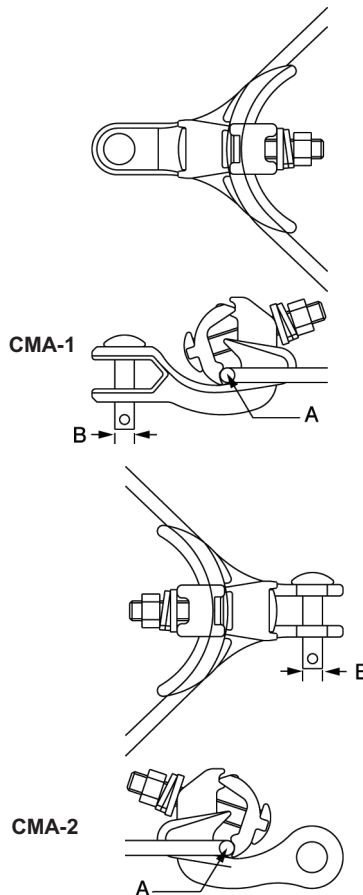
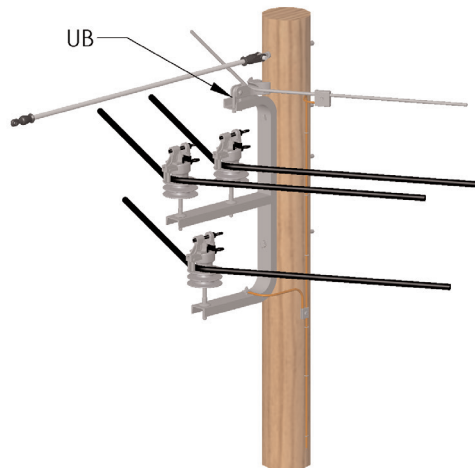
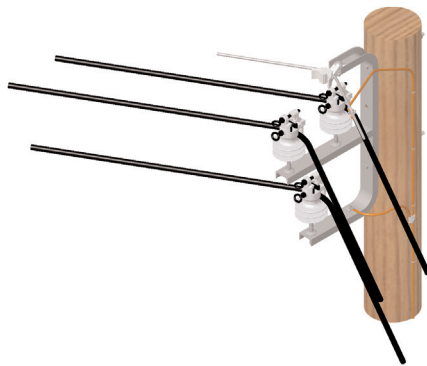

Part Number	Dimensions (in)			Max. Line Angle (degrees)	Min. Ultimate Load (lbs)	Weight (lbs)	Material
	A	B	C				
CMA-1	.23 - .75	5/8	—	60°	11,000	2.4	HDG Ductile Iron
CMA-2	.16 - .75	5/8	—	60°	11,000	2.1	HDG Ductile Iron
UB	1.5	5/16 - 12 UNC	4.25	—	—	1.1	Galvanized Steel

2IP Double Insulator Plate



Description:

The 2IP Double Insulator Plate is an accessory that allows two Hendrix HPI polyethylene insulators to be used at each phase position on all Hendrix angle brackets. The 2IP is cast ductile iron that is hot dip galvanized after fabrication.

Benefits:

- Provides an increased phase conductor bend radius.
- Divides the mechanical load of large angles between two insulator pins.

Application:

Each 2IP plate is furnished with the required hardware for mounting on all Hendrix angle brackets. Compatible with 3" or 4" wide channel.

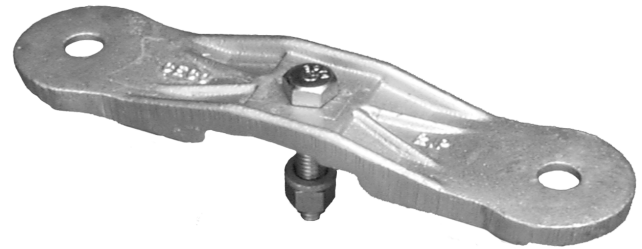

Part Number	System Voltage	Line Angle	Conductor Size	2IP Insulator Plate
2IP	15kV	7° - 60°	All	Not Required
		61° - 90°	All	Required
	25/35kV	7° - 44°	All	Not Required
		45° - 60°	Below 336.4	Not Required
		45° - 60°	336.4 and larger	Required
		61° - 90°	All	Required

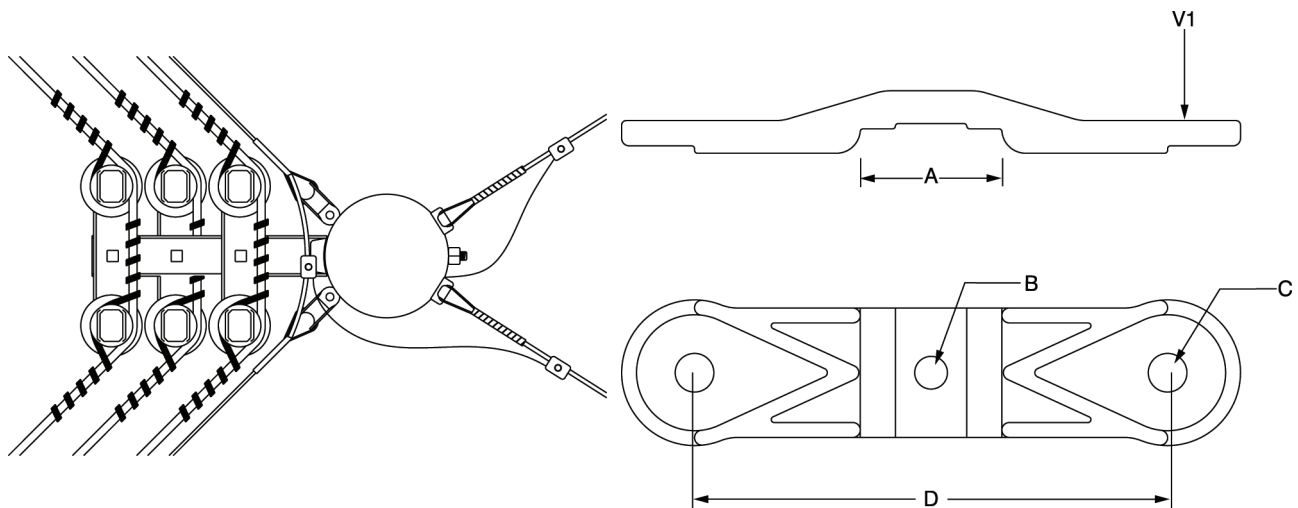

Part Number	Dimensions (in)				Min. Ultimate Load V1 (lbs)	Weight (lbs)	Material
	A	B	C	D			
2IP	3.125	1 ¹ / ₁₆	1 ¹ / ₁₆	10	1,750	3.9	HDG Ductile Iron

SSP-2, LSP-1 Insulator Pins



Description:

Use Hendrix SSP-2 pins for mounting polymer pin insulators. The SSP-2 and LSP-1 are insulator pins used to mount Hendrix polyethylene insulators on Hendrix Spacer Cable brackets and standard crossarms. Both insulator pins are supplied with the ANSI standard 1.0" thread. The insulator pin body is forged steel that is hot dip galvanized.

Benefit:

The SSP-2 has a non-standard 2.0" base diameter which permits the insulator pins to be used with Hendrix angle, tap and dead-end brackets fabricated from 3.0" structural steel channel.

Application:

These insulator pins should be used with Hendrix polyethylene insulators when used with spacer cable or tree wire systems. The SSP-2 is a short shank pin designed for use with Hendrix fabricated metal brackets. The LSP-1 is a long shank pin for use with standard crossarms.



SSP-2



LSP-1

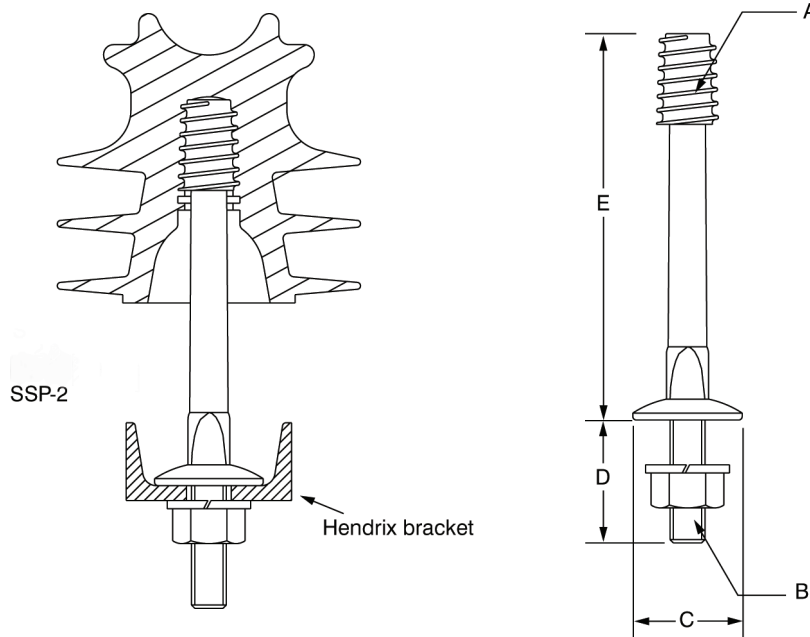

Part Number	Dimensions (in)					Weight (lbs)	Material
	A	B	C	D	E		
SSP-2	1.0 ANSI Standard	3/4 - 10 UNC	2.0	2.375	7.0	1.9	Galvanized Steel
LSP-1	1.0 ANSI Standard	3/4 - 10 UNC	2.75	6.5	7.0	2.9	Galvanized Steel

Contact Hendrix for Mechanical load capacity ratings.

SC Shackle Clevis

Description:

The Hendrix SC Shackle Clevis is used for attaching dead-end insulators to Hendrix dead-end brackets. It is made of hot dip galvanized steel.

Part Number	Weight (lbs)	Min. Ultimate Load (lbs)
SC	0.92	20,000

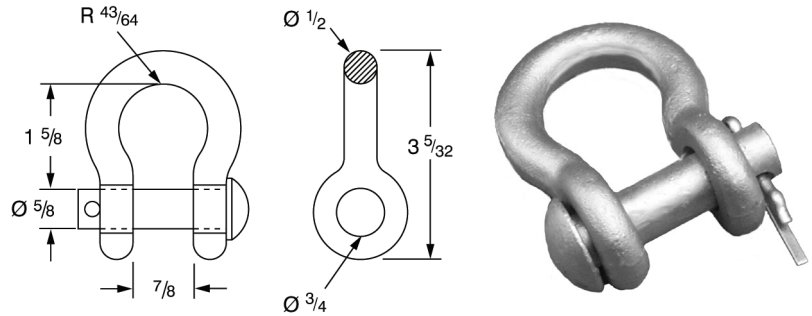

TC Thimble Clevis

Description:

The Hendrix TC Thimble Clevis is used on the looped end of preformed conductor and messenger grips in order to evenly distribute the mechanical stress. It is made of galvanized pressed steel. When messenger tension, plus applicable safety factors, exceed 2,500 lbs., the Hendrix HDTC Thimble Clevis must be used.

Part Number	Weight (lbs)	Safe Working Load (lbs)
TC	1.1	2,500

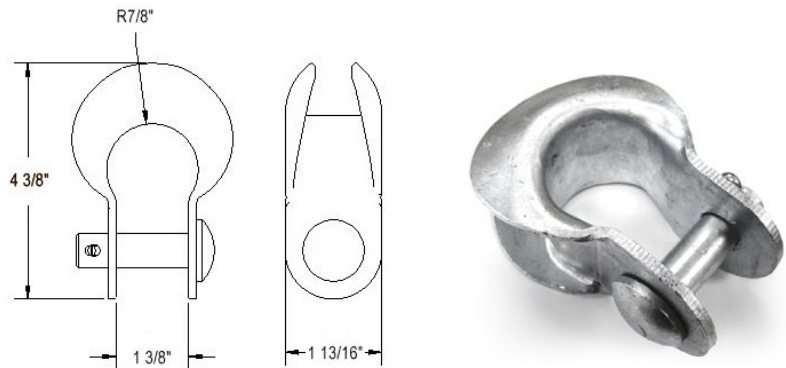

HDTC Heavy Duty Thimble Clevis

Description:

The Hendrix HDTC Heavy Duty Thimble Clevis is used on the looped end of preformed messenger grips in order to evenly distribute the mechanical stress. It is made of galvanized steel.

Part Number	Weight (lbs)	Min. Ultimate Load (lbs)
HDTC	2.6	40,000

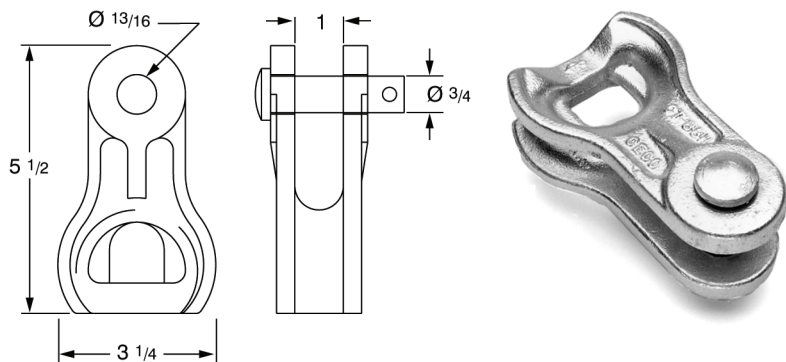

DEINS15, DEINS25, DEINS35 Polymer Dead-end Insulators



Description:

Dead-end insulators consist of a fiberglass core with a polymeric sheath and weathersheds. End fittings are galvanized steel. Insulators are available for 15kV through 35kV systems.

Benefits:

- Lightweight
- Unbreakable
- Vandal resistant
- Excellent weatherability

Application:

Polymer dead-end insulators are used to electrically isolate the phase conductors from ground. They are suitable for use on Spacer Cable or Tree Wire Systems. The use of a shackle clevis is recommended when attaching dead-end insulators to Hendrix dead-end brackets.

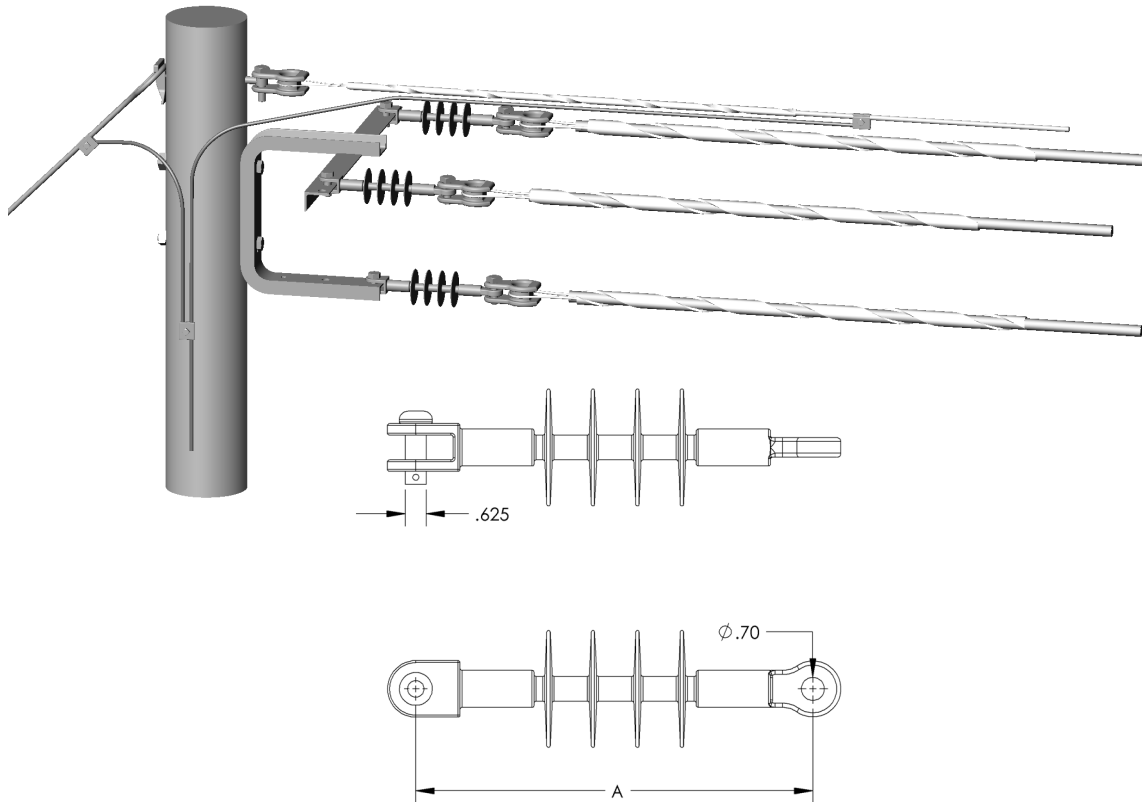
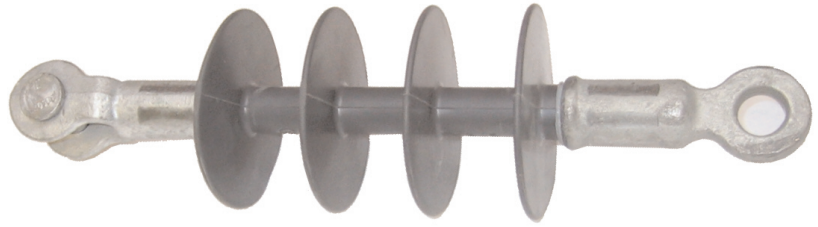

Part Number	System Voltage	Length "A" (in)	Leakage Distance (in)	Rated Tensile Load (lbs)	Low Frequency Flashover (kV)		Critical Impulse Flashover (kV)	
					Dry	Wet	Positive	Negative
DEINS15	15kV	12.5	16.0	7,500	110	75	140	160
DEINS25	25kV	18.75	31.0	7,500	150	130	260	280
DEINS35	35kV	19.63	33.0	7,500	200	160	325	360

XPT-30 Pole Top Extension



Description:

The XPT-30 is a pole top extension used with Hendrix Spacer Cable Systems. The bracket is formed using 4.0" channel and is hot dip galvanized after fabrication.

Benefits:

- Eliminates the need for costly pole replacement
- Provides additional clearance between primary circuit(s) and under-built utilities
- 8.0" mounting hole spacing conforms to standard pre-drilled poles for ease of installation

Application:

The XPT-30 can be used on both tangent and angle structures where an additional 12.0" of pole height is required. This pole top extension will accommodate any tangent or angle bracket with 8.0" mounting hole spacing. Observance of proper guying practices is critical on angle structures. Pole mounting is accomplished using thru-bolts (not included).

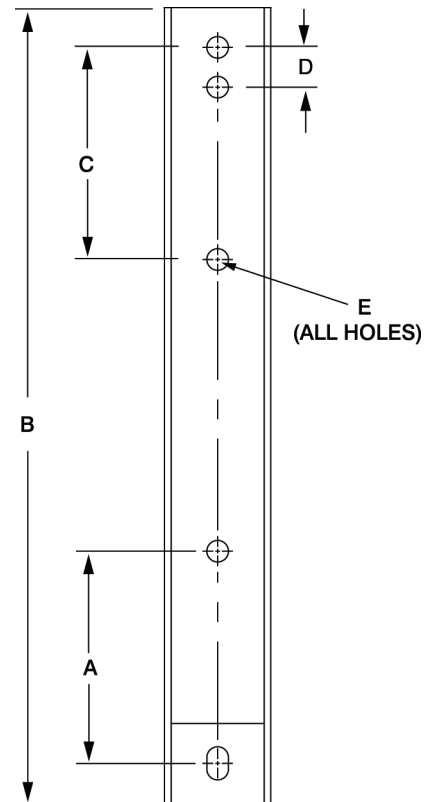
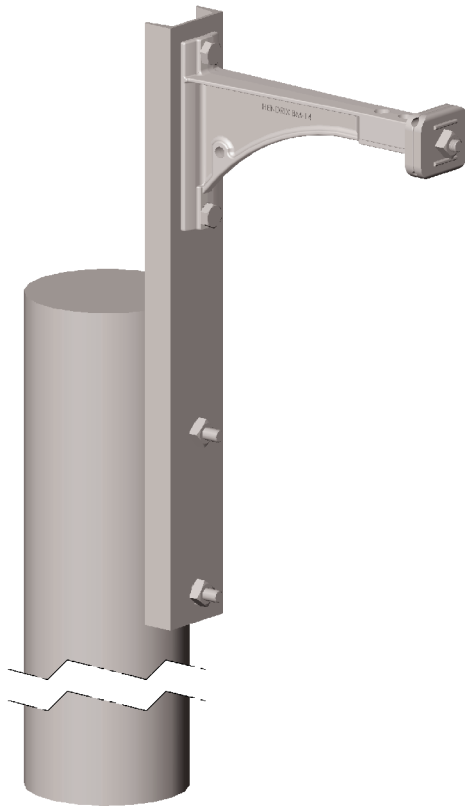

Part Number	Dimensions (in)					Weight (lbs)	Material
	A	B	C	D	E		
XPT-30	8	30	8	1.5	1 ³ / ₁₆	16	HDG ASTM A-36 Structural Steel

XPT-60, XPT-60H, XPT-75, XPT-75H Pole Top Extensions



Description:

The XPT-60, XPT-60H, XPT-75 and XPT-75H are pole top extensions used with Hendrix Spacer Cable Systems. The brackets are formed using 4.0" channel and 2.0" angle and are hot dip galvanized after fabrication.

Benefits:

- Eliminates the need for costly pole replacement
- Provides additional clearance between primary circuit(s) and under-built utilities
- XPT-60, XPT-60H extend pole up to an additional 44.0"
- XPT-75, XPT-75H extend pole up to an additional 59.0"
- 8.0" mounting hole spacing conforms to standard pre-drilled poles for ease of installation
- Brackets are designed to accept all Hendrix pole mounted hardware, eliminating the need for special construction standards

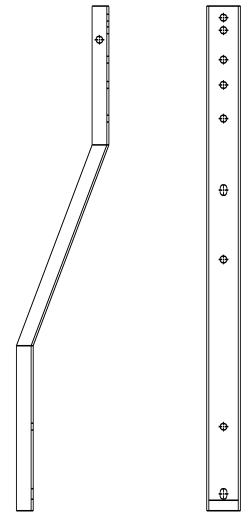

Application:

The XPT-60 and XPT-75 are pole-top extensions that can be used on both tangent and angle structures where additional pole height is required. The XPT-60H and XPT-75H have two 4.0" channel sections to provide additional strength when required by circuit loading conditions. Contact Hendrix for assistance in selecting the proper pole top extension. Observance of proper guying practices is critical on angle structures. Hardware required for assembly of pole-top extensions is furnished. Pole mounting is accomplished using thru-bolts (not included).

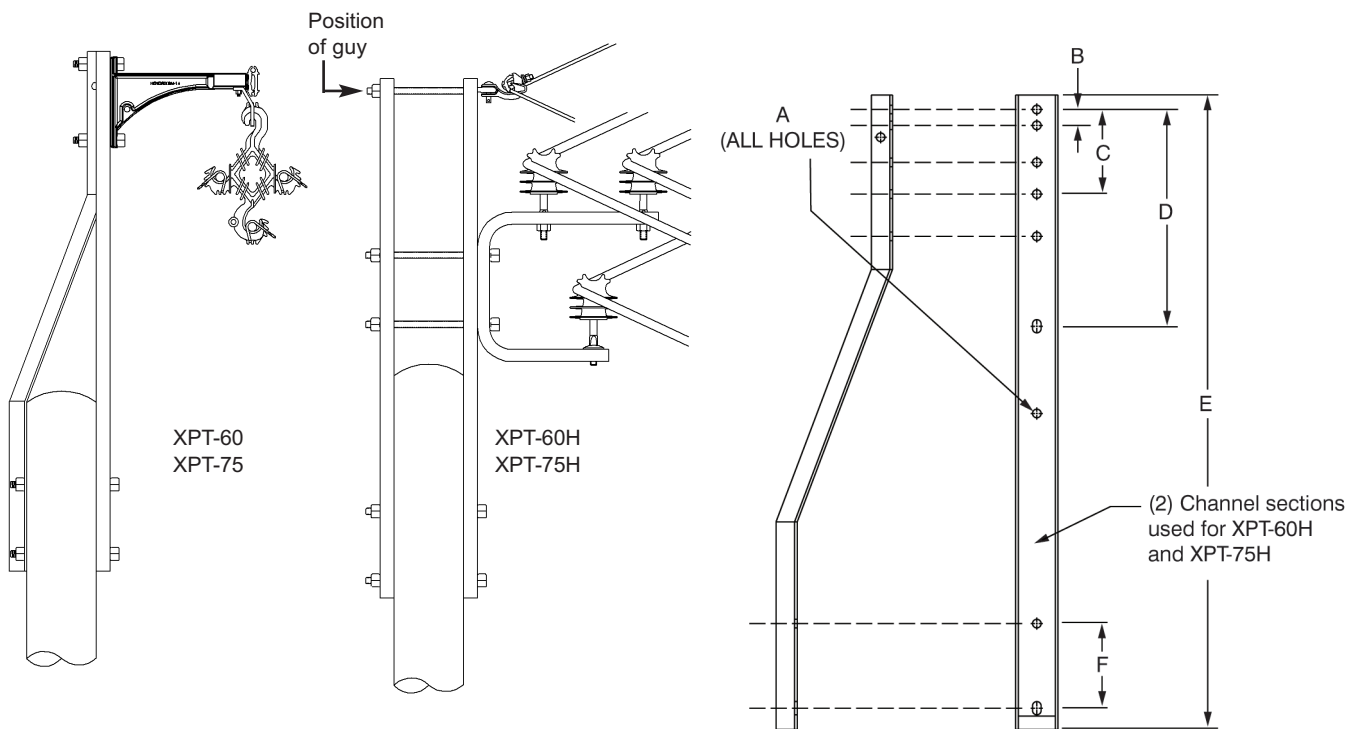

Note: Double arming bolt supplied with XPT-75

Part Number	Dimensions (in)						Weight (lbs)	Material
	A	B	C	D	E	F		
XPT-60	1 ³ / ₁₆	1.5	8	20.5	60	8	41.5	HDG ASTM A-36 Structural Steel
XPT-60H	1 ³ / ₁₆	1.5	8	20.5	60	8	56.0	HDG ASTM A-36 Structural Steel
XPT-75	1 ³ / ₁₆	1.5	8	20.5	75	8	55.0	HDG ASTM A-36 Structural Steel
XPT-75H	1 ³ / ₁₆	1.5	8	20.5	75	8	69.0	HDG ASTM A-36 Structural Steel

CG-0114 Through CG-0128 Conductor Dead-end Grips



Description:

CG grips are neoprene coated, pre-formed type grips for dead-ending Hendrix spacer cables.



Application:

CG grips are used in spacer cable systems to dead-end the phase conductors. They are applied directly over the covering. No stripping is required. The CG grips are partial tension devices and should only be used with messenger supported spacer cable conductors. Automatic dead-end grips should not be used on spacer cable conductors.

Part Number	Cable Diameter Range (in)		Weight (lbs)	Length (in)	Color Code
	Minimum	Maximum			
CG-0114	0.609	0.648	1.0	33	Red
CG-0115	0.649	0.690	1.0	34	Green
CG-0116	0.691	0.735	1.2	35	Black
CG-0117	0.736	0.783	1.3	36	Orange
CG-0118	0.784	0.834	1.4	38	Blue
CG-0119	0.835	0.888	1.6	40	Black
CG-0120	0.889	0.945	1.8	42	Yellow
CG-0121	0.946	1.005	2.1	44	Green
CG-0122	1.006	1.070	2.4	45	Red
CG-0123	1.071	1.138	2.4	47	Blue
CG-0124	1.139	1.212	3.0	48	Orange
CG-0125	1.213	1.288	3.0	49	Black
CG-0126	1.289	1.372	3.2	51	Yellow
CG-0127	1.373	1.458	3.8	53	Green
CG-0128	1.459	1.550	4.0	56	Red

MG Messenger Dead-end Grips

MS Messenger Splices



MG-4122, MG-4128, MG-4131, MG-4179 Messenger Dead-end Grips

Description:

The MG-4122, MG -4128, MG-4131 and MG-4179 Messenger Dead-end Grips are pre-formed type grips for dead-ending spacer cable messenger wire.

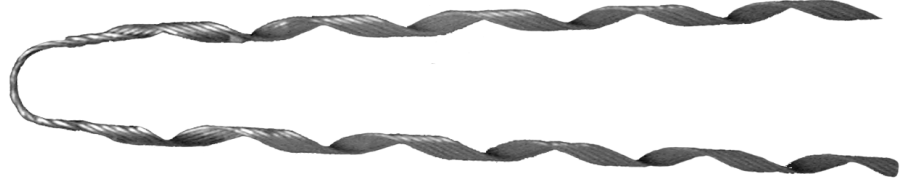

Application:

Messenger dead-end grips have a holding strength equal to the messenger strength. A thimble clevis must be used to prevent damage to the loop of the messenger grip.

Part Number	Messenger Wire	Weight (lbs)	Length (in)	Color Code
MG-4122	7 #8 AW 252 AWA	1.1	32	Orange
MG-4128	7 #6 AW 052 AWA	2.3	39	Blue
MG-4131	2/0 AW 0052 AWA	3.2	44	Yellow
MG-4179	4/0 AW 0000127 AWA	7.0	63	Black

MS-4122, MS-4128, MS-5272, MS-3258 Messenger Splices

Description:

The MS-4122, MS-4128, MS-3258 and MS-5272 are pre-formed type splices for connecting two lengths of messenger wire. The splices consist of three sets of spirally formed rods.



Application:

Messenger splices are used for splicing or repairing messenger wire. Messenger splices have a holding strength equal to the messenger strength. To restore full conductivity, a bare aluminum jumper wire should be installed across the splice.

Part Number	Messenger Wire	Weight (lbs)	Length (in)	Color Code
MS-4122	7 #8 AW 252 AWA	1.4	38	Orange
MS-4128	7 #6 AW 052 AWA	3.0	55	Blue
MS-5272	0052 AWA	4.4	64	Yellow
MS-3258	0000127 AWA	8.0	88	Green

Cold Shrink Splice Cover Kits-Type KM

Description:

Cold Shrink Splice Cover Kits are designed to be an easy-to-install, safe and fast method of covering splices on Spacer Cable. Each kit contains a 3MTM Silicon Rubber Cold Shrink Tube, Rubber Mastic Tape, Semicon Tape, Mastic, Compression Sleeve, and installation instructions. The tubes are open-ended rubber sleeves which are factory-expanded and assembled onto removable plastic cores. After the tube has been positioned for installation over an in-line splice, the core is removed, thus allowing the tube to shrink and seal the splice.

Kit Now Includes Partial Tension Compression Sleeve.



Removing the core

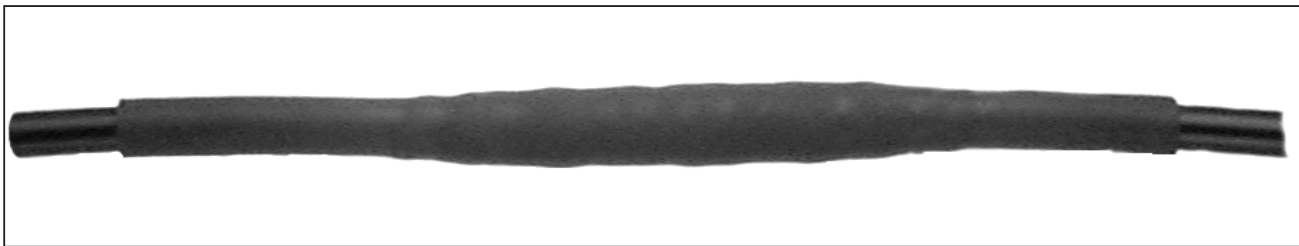

Completed splice cover

Benefits:

- All required components and instructions are provided in one kit
- Simple, safe installation, requires no tools
- Accommodates covered cables with various outside diameters (see table on other side)
- No torches or heat are required
- Significantly reduces the time required to cover splices by traditional techniques
- Maintains the physical and electrical integrity of the covered conductor
- Includes partial tension compression sleeve

Application:

Cold Shrink Splice Cover Kits are used for sealing splices on covered conductor overhead electrical distribution circuits such as spacer cable. Splice cover kits are available for systems rated 46kV and below. The kits are suitable for use over a range of cable diameters for each system voltage as shown in the table on other side. Consult Hendrix for applications which are outside the ranges shown. The components of the kit are applied to a splice as shown in the cross-sectional drawing on other side. Installation instructions are furnished with each kit.

Application: (continued)

KM KIT TABLE 15-25kV

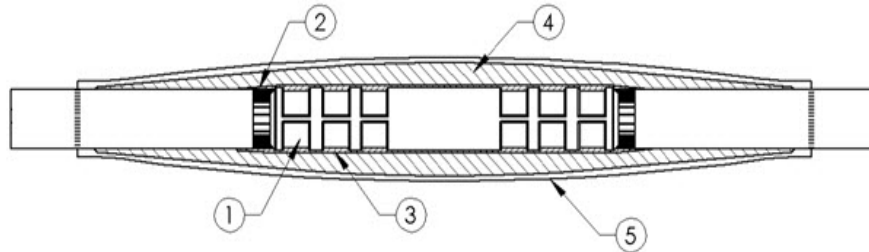

1. Partial Tension Compression Sleeve
2. Strips - 3M™ Insulating Mastic
3. Roll - 3M™ Semi-conducting Tape
4. 3M™ Rubber Mastic Tape
5. 3M™ Cold Shrink Silicone Splice Tube (Length of the tube is approximately 22")

Part Number	System Voltage (kV)	Conductor Size (AWG/KCM)	Compression Sleeve	Cable Catalog Number
KM15-10	15	1/0	YDS25AT	S0010PA15B3-00 / S0010PA15G3-00
KM15-20	15	2/0	YCS26A	S0020PA15B3-00 / S0020PA15G3-00
KM15-30	15	3/0	YCS27A	S0030PA15B3-00 / S0030PA15G3-00
KM15-40	15	4/0	YCS28A	S0040PA15B3-00 / S0040PA15G3-00
KM15-266	15	266	YCS291A	S0266PA15B3-00 / S0266PA15G3-00
KM15-336	15	336	YCS301A	S0336PA15B3-00 / S0336PA15G3-00
KM15-397	15	397	YCS311A	S0397PA15B3-00 / S0397PA15G3-00
KM15-477	15	477	YCS331A	S0477PA15B3-00 / S0477PA15G3-00
KM15-556	15	556	YCS351A	S0556PA15B3-00 / S0556PA15G3-00
KM15-636	15	636	YCS361A	S0636PA15B3-00 / S0636PA15G3-00
KM15-795	15	795	YCS391A	S0795PA15B3-00 / S0795PA15G3-00
KM25-10	25	1/0	YDS25AT	S0010PA25B3-00 / S0010PA25G3-00
KM25-20	25	2/0	YCS26A	S0020PA25B3-00 / S0020PA25G3-00
KM25-30	25	3/0	YCS27A	S0030PA25B3-00 / S0030PA25G3-00
KM25-40	25	4/0	YCS28A	S0040PA25B3-00 / S0040PA25G3-00
KM25-266	25	266	YCS291A	S0266PA25B3-00 / S0266PA25G3-00
KM25-336	25	336	YCS301A	S0336PA25B3-00 / S0336PA25G3-00
KM25-397	25	397	YCS311A	S0397PA25B3-00 / S0397PA25G3-00
KM25-477	25	477	YCS331A	S0477PA25B3-00 / S0477PA25G3-00
KM25-556	25	556	YCS351A	S0556PA25B3-00 / S0556PA25G3-00
KM25-636	25	636	YCS361A	S0636PA25B3-00 / S0636PA25G3-00
KM25-795	25	795	YCS391A	S0795PA25B3-00 / S0795PA25G3-00

Cold Shrink Splice Cover Kits-Type KM

Application: (continued)

KM KIT TABLE 15-25kV

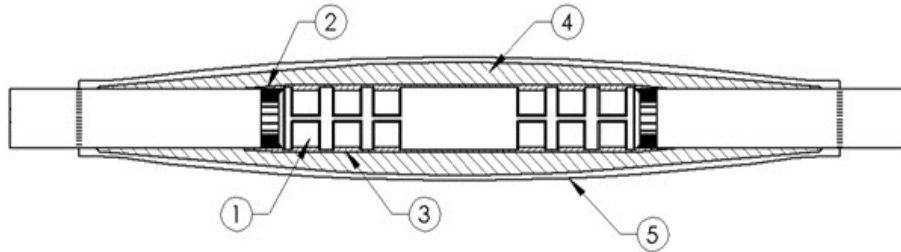

1. Partial Tension Compression Sleeve
2. Strips - 3M™ Insulating Mastic
3. Roll - 3M™ Semi-conducting Tape
4. 3M™ Rubber Mastic Tape
5. 3M™ Cold Shrink Silicone Splice Tube (Length of the tube is approximately 22")

Part Number	System Voltage (kV)	Conductor Size (AWG/KCM)	Compression Sleeve	Cable Catalog Number
KM35-10	35	1/0	YDS25AT	S0010PA35B3-00 / S0010PA35G3-00
KM35-20	35	2/0	YCS26A	S0020PA35B3-00 / S0020PA35G3-00
KM35-30	35	3/0	YCS27A	S0030PA35B3-00 / S0030PA35G3-00
KM35-40	35	4/0	YCS28A	S0040PA35B3-00 / S0040PA35G3-00
KM35-266	35	266	YCS291A	S0266PA35B3-00 / S0266PA35G3-00
KM35-336	35	336	YCS301A	S0336PA35B3-00 / S0336PA35G3-00
KM35-397	35	397	YCS311A	S0397PA35B3-00 / S0397PA35G3-00
KM35-477	35	477	YCS331A	S0477PA35B3-00 / S0477PA35G3-00
KM35-556	35	556	YCS351A	S0556PA35B3-00 / S0556PA35G3-00
KM35-636	35	636	YCS361A	S0636PA35B3-00 / S0636PA35G3-00
KM35-795	35	795	YCS391A	S0795PA35B3-00 / S0795PA35G3-00
KM46-10	46	1/0	YDS25AT	S0010PA46B3-00 / S0010PA46G3-00
KM46-20	46	2/0	YCS26A	S0020PA46B3-00 / S0020PA46G3-00
KM46-30	46	3/0	YCS27A	S0030PA46B3-00 / S0030PA46G3-00
KM46-40	46	4/0	YCS28A	S0040PA46B3-00 / S0040PA46G3-00
KM46-266	46	266	YCS291A	S0266PA46B3-00 / S0266PA46G3-00
KM46-336	46	336	YCS301A	S0336PA46B3-00 / S0336PA46G3-00
KM46-397	46	397	YCS311A	S0397PA46B3-00 / S0397PA46G3-00
KM46-477	46	477	YCS331A	S0477PA46B3-00 / S0477PA46G3-00
KM46-556	46	556	YCS351A	S0556PA46B3-00 / S0556PA46G3-00
KM46-636	46	636	YCS361A	S0636PA46B3-00 / S0636PA46G3-00
KM46-795	46	795	YCS391A	S0795PA2463-00 / S0795PA46G3-00

PBR-3-DR Roll-By Block, QRS-02 Messenger Trolley, TL-30 Tag Line



Description:

The PBR-3-DR, QRS-02 and TL-30 are the pieces of installation equipment required to install Hendrix Spacer Cable Systems using the Roll-By Installation Method. The PBR-3-DR has a cast aluminum frame, a dual aluminum messenger roller assembly and polymer conductor sheaves. The QRS-02 has a cast stainless steel frame with a detachable ductile iron sled. The TL-30 Tag Line is a 30 ft. polyester rope that is supplied for easy attachment to the PBR-3-DR Roll-By blocks.

Benefits:

- Permits the installation of all three phase conductors simultaneously
- Compatible with Hendrix “BM” series tangent brackets permitting continuous uninterrupted pulling past tangent structures
- Phase conductors are supported every thirty feet during installation, dramatically reducing sag between poles. Ideal for installations where the Hendrix Spacer Cable circuit is being built over an existing distribution circuit and for circuits that cross heavily traveled roads
- Obtaining proper phase conductor sag is quick and easy
- Simplifies the location of Hendrix spacers during the final stage of installation
- The QRS-02 keeps the conductor separated for better alignment with the PBR-3-DR Roll-By blocks
- The QRS-02 is detachable and is designed to pass through a three sheave block.

Application:

A detailed Installation guide for the roll-by method is available from Hendrix specifying PBR-3-DR Roll-By Blocks and TL-30 Tag Lines for an installation, the required number of each is equal to the longest pulling section in feet divided by thirty.

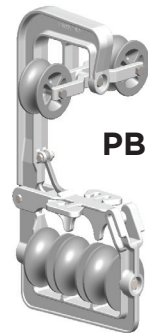

PBR-3-DR



QRS-02

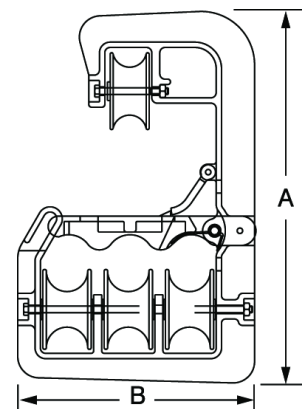
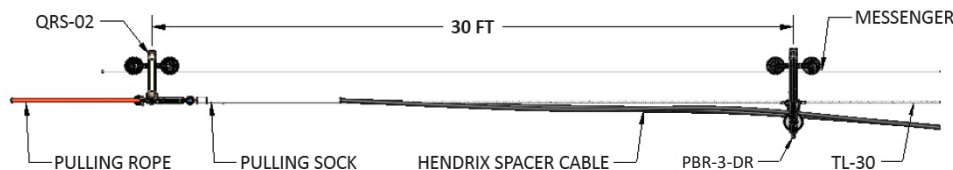

Part Number	Dimensions (in)		Max. Conductor Diameter (in)	Weight (lbs)	Material
	A	B			
PBR-3-DR	19.5	11.125	2	9.5	Cast Aluminum
QRS-02	33.19	6.88	—	37.0	AISI 304 SS
TL-30	See description above			1.2	Polyester Rope

Description:

The QR-SLED-02 is a piece of installation equipment for installing Hendrix Spacer Cable Systems and can be attached to or detached from the lead trolley, TMS-DR, via a set of disconnect pins, so it can be used for the Roll-By Installation Technique.

The QR-SLED-02 also has a set of weighted tails that helps to stabilize the cables when stringing around corners by keeping them right side up and is designed to smoothly fit through the 3SB-02 Three Sheave Stringing Blocks, so it can be used for the Pole By Pole Installation Technique.



Benefits:

- The QR-SLED-02 can be attached or detached from the lead trolley and is designed to pass through the 3SB-02 three sheave block, so it can be used for both installation methods.
- Weighted tails help keep cable from getting twisted during stringing.
- Made from cast stainless steel.
- It smoothly passes through the 3SB-02 stringing blocks.
- Versatile design. Can be used for Roll-By and Pole By Pole installation techniques.

Application:

A detailed Installation guide for the Roll-By Method is available from Hendrix specifying QRS-02, PBR-3-DR Roll-By Blocks, and TL-30 Tag Lines for an installation. Also a detailed installation guide is available for the Pole By Method specifying the QR-Sled-02 and 3SB-02 is also available from Hendrix.

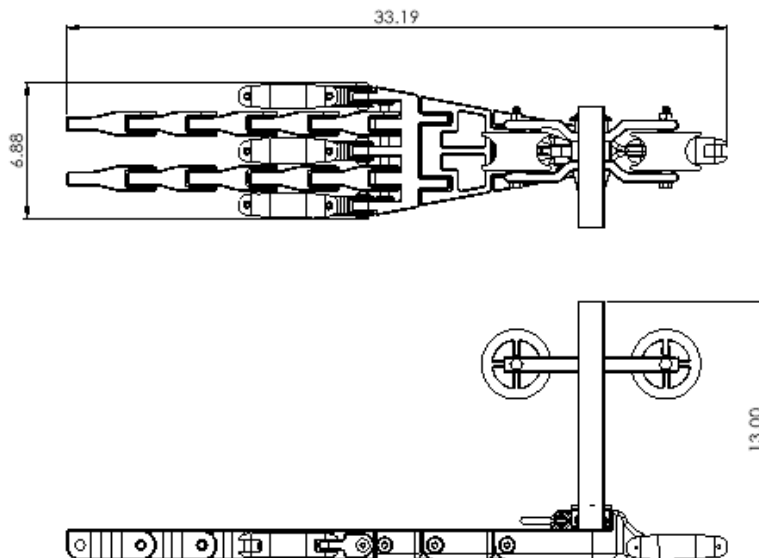

Part Number	Dimensions (in)			Weight (lbs)	Material
QR-SLED-02	33.19	6.88	2.48	37.0	AISI 304 SS

3SB-02 - Three Sheave Stringing Block

Description:

This three sheave block is primarily used to support phase cables at dead end poles and facilitate cable placement at angle poles during cable installation. During "pole by pole method" installations, they can be hung mid-span from the messenger at regular intervals to support the cables.

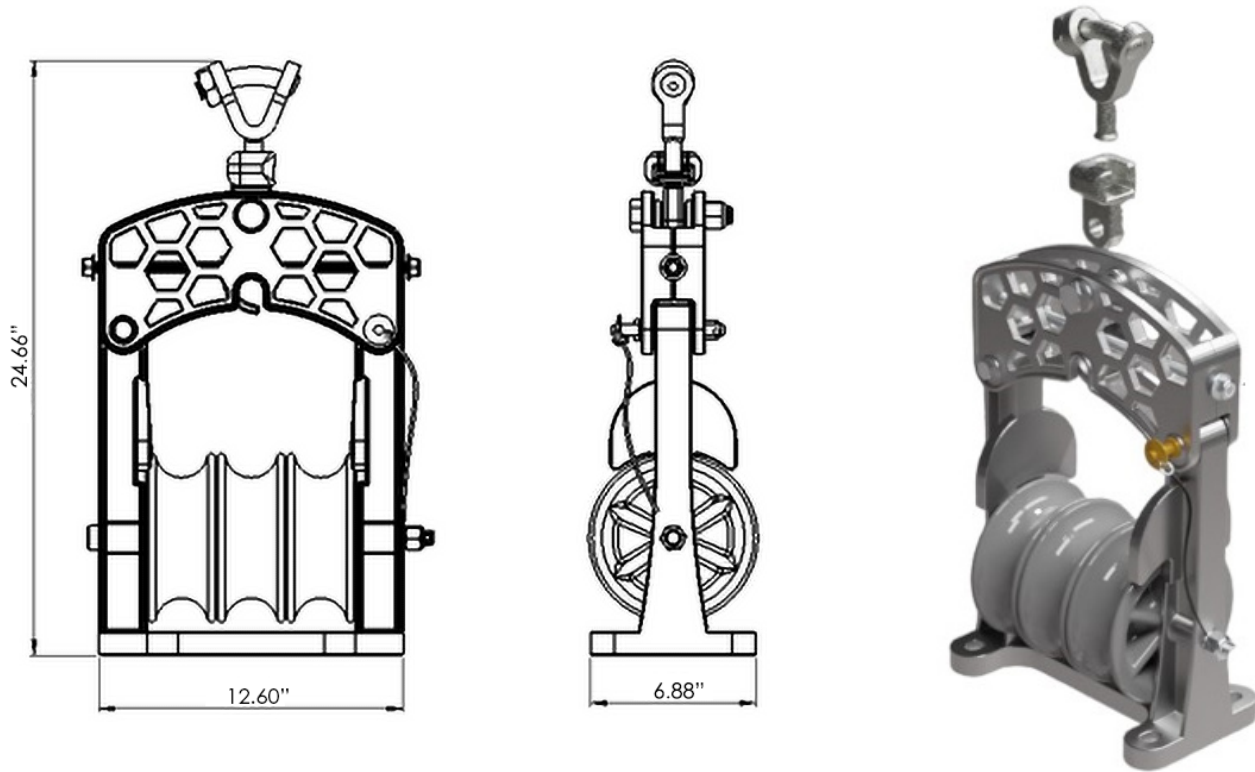

PAT-1 Angle Tensioning Block



Description:

The PAT-1 is designed to facilitate messenger installation on Hendrix Spacer Cable Systems. The Angle Tensioning Block is cast aluminum and is furnished complete with all required mounting hardware.

Benefits:

- Messenger can be tensioned while in the PAT-1
- The PAT-1 is a less expensive alternative to standard, single sheave roller blocks

Application:

The PAT-1 is used for messenger installation on all angles greater than 6°. The Angle Tensioning Block is used in the same manner as any single sheave roller block.

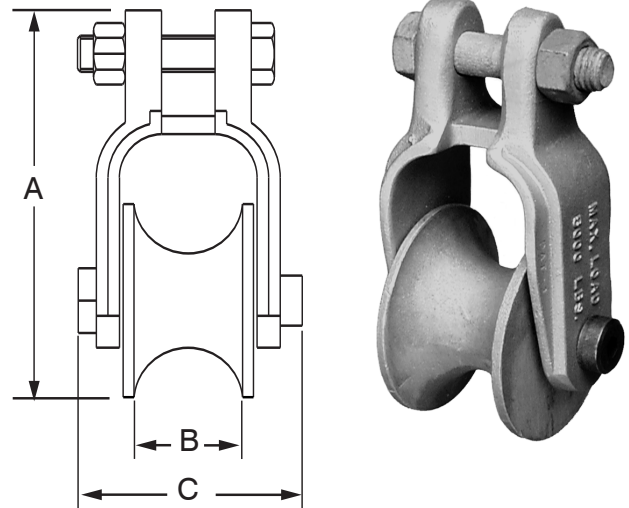

Part Number	Dimensions (in)			Weight (lbs)	Maximum Load Rating (lbs)	Material
	A	B	C			
PAT-1	6 11/16	1 7/8	3 7/8	2.5	5,000	Cast Aluminum

PAS-1 Angle Stringing Block



Description:

The PAS-1 is a single sheave stringing block used to pull phase conductors through angles when installing Hendrix Spacer Cable Systems using the Roll-By installation method. It has a cast aluminum frame and roller. The hardware needed to attach the PAS-1 to an angle bracket is included.

Benefits:

- Can be used to pull conductors through angles up to 90°
- Conductors can be sagged while in the blocks
- Latch keeps conductors from slipping out of the blocks
- Positions the conductors for easy replacement with pins and insulators
- May be positioned vertically for stringing single conductors on crossarms

Application:

The PAS-1 is intended for low tension pulling of the phase conductors. The PAS-1 may be used with any of the Hendrix angle brackets and will accommodate cable diameter up to 1.625". Two PAS-1 blocks per phase should be used wherever a 2IP Double Insulator Plate is required.

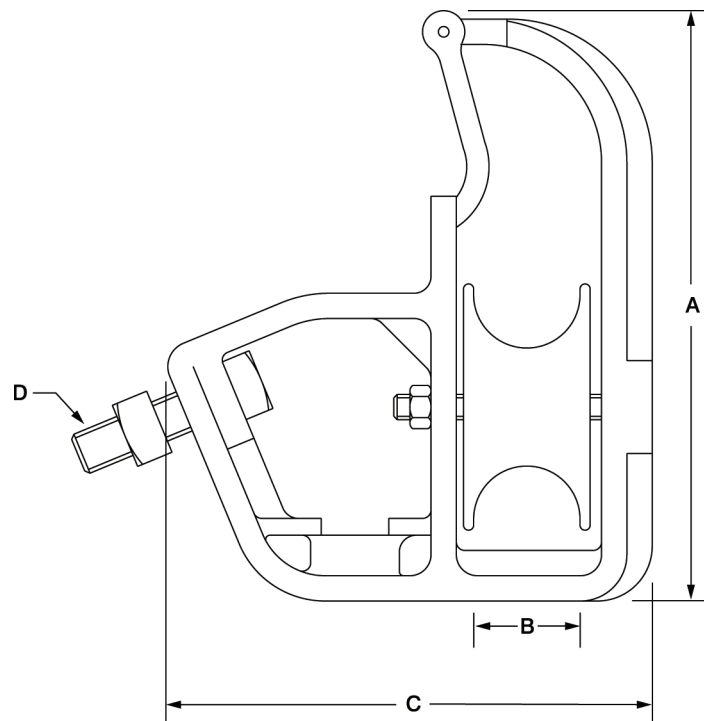
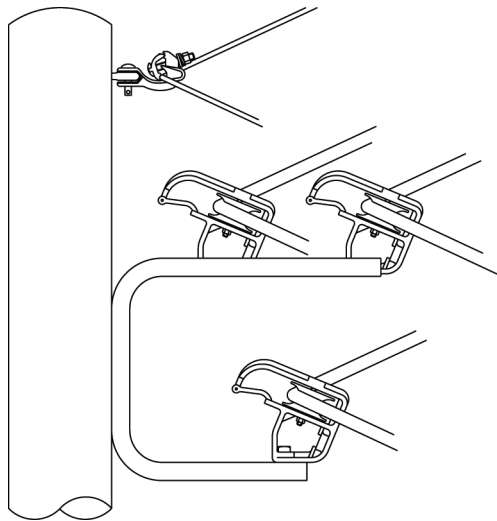
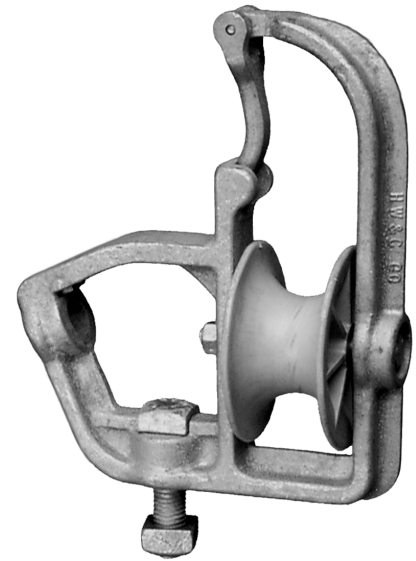

Part Number	Dimensions (in)				Weight (lbs)	Material
	A	B	C	D		
PAS-1	8 5/8	1 1/16	7 3/16	5/8-11unc	2.0	Cast Aluminum

BJ Slack Bracket



Description:

The BJ Slack Bracket is designed to support the rope that is used to pull in the phase conductors when the Roll-By Installation Method is used to install Hendrix Spacer Cable Systems.

Benefits:

- Attaches quickly and easily to Hendrix BM-14 and BM-24 tangent brackets
- Roller helps provide smooth, resistance free pull
- Keeps pulling rope off the ground, minimizing wear and reducing clearance problems when over-building existing utilities and at road crossings

Application:

The BJ Slack Brackets can be installed on the tangent brackets as the poles are being framed. Attachment to the tangent bracket is accomplished with a stainless steel hook. A canvas belt is provided to secure the roller end of the bracket to the pole. The BJ Slack Bracket is designed to support the pulling rope only and should not be used to install cable.

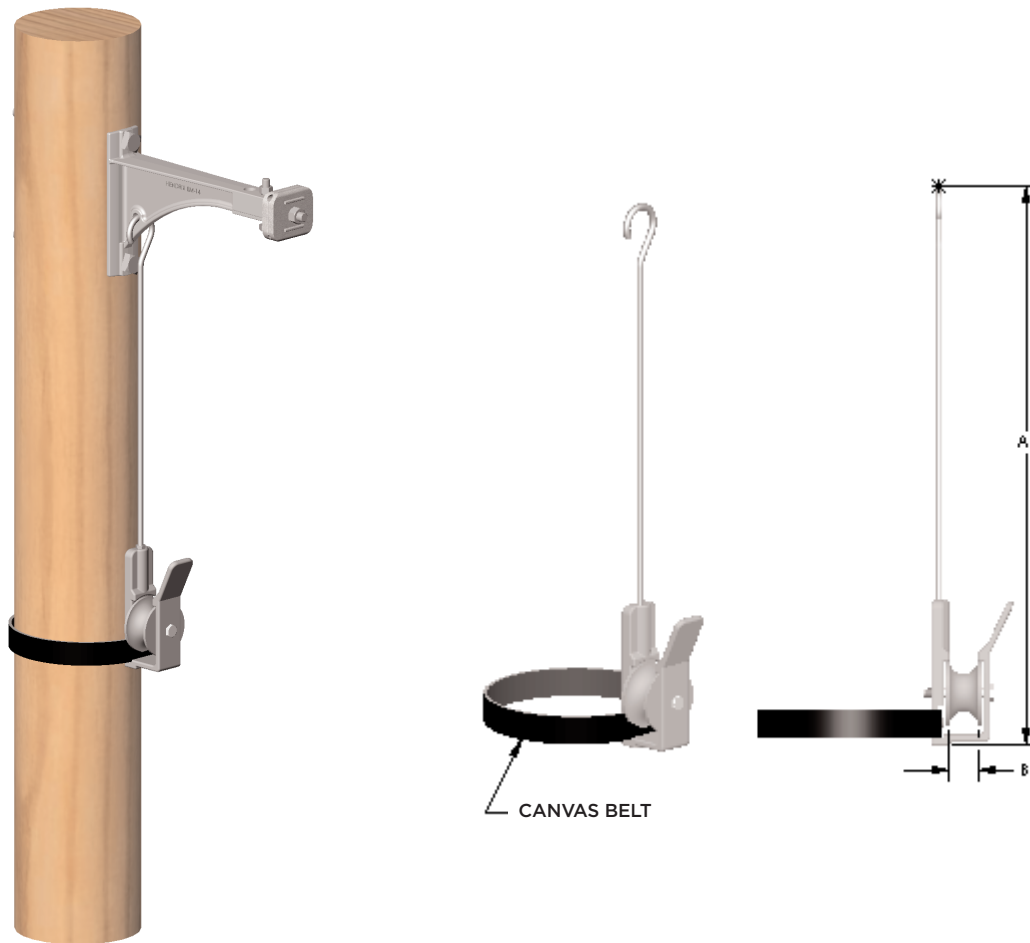

Part Number	Dimensions (in)		Weight (lbs)	Ultimate Vertical Load (lbs)
	A	B		
BJ	29 5/8	1 1/2	3.2	800

CMC-2 Underarm Messenger Clamp



Description:

The CMC-2 Underarm Messenger Clamp is used with Hendrix Type BM tangent brackets. It is made of cast aluminum-bronze and includes the MC-2 messenger clamp with bolt.

Benefits:

- Saves on installation labor by allowing PBR-3-DR Roll-By Blocks to pass pole when circuit changes pole sides.
- Compatible with Hendrix Type BM tangent brackets.
- The CMC-2 may be secured to a crossarm for underarm installations. clearance problems when over-building existing utilities and at road crossings

Application:

The CMC-2 is used for installation of conductors at tangent poles when the circuit changes pole sides. It is used with tangent brackets to allow the messenger trolley and roll-by blocks to pass the pole and is attached to the end of Hendrix tangent brackets with a 5/8 inch bolt. The messenger is secured with the included MC-2 messenger clamp. The CMC-2 should be removed after installation and the messenger secured directly on the BM tangent bracket. The CMC-2 may also serve as a permanent support bracket for underarm spacer cable installations.



Installation Tool

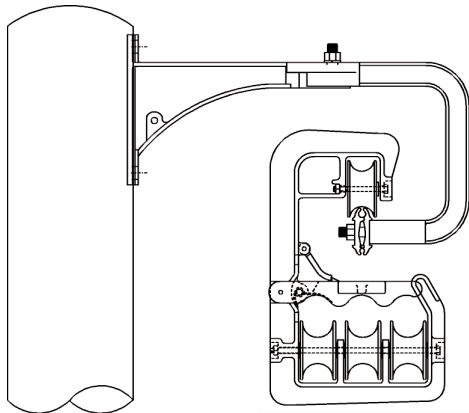

Underarm Bracket Application

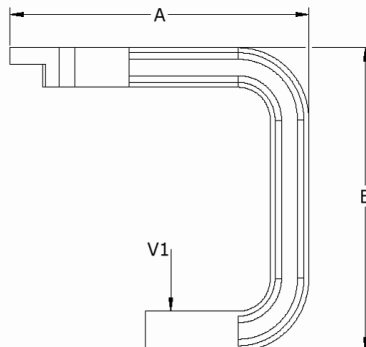
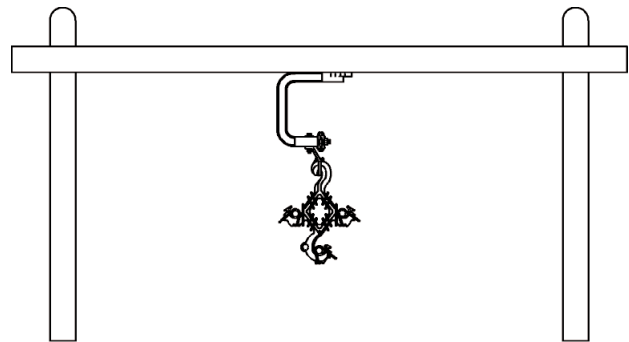

Part Number	Dimensions (in)		Weight (lbs)	Min. Ultimate Load (lbs) V1 (vertical)	Material
	A	B			
CMC-2	11 1/2	11 1/2	10.0	4,000	Alum. Bronze

Description:

Two companies offer stripping tools that facilitate the removal of the covering on Hendrix Spacer Cable and Tree Wire. They provide reliable means of completing both end and mid-span strips.



Ripley Fixed Conductor Stripping Tool
WS Series*
www.ripley-tools.com

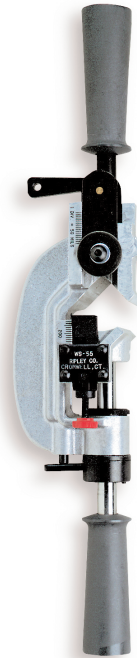

Ripley Adjustable Stripping Tool
WS-55
www.ripley-tools.com



Speed Systems Adjustable Tool
Model 2900
www.spdsystems.com

*When ordering a WS series tool, please provide the following information (see Hendrix catalog for cable information).

- Conductor size and diameter
- Insulation thickness
- Outside diameter of cable $+.020/-0.010$

Stripping tools can be ordered from the manufacturer or directly from Hendrix

Description:

Hendrix pulling grips are an installation accessory used for pulling covered overhead conductors during installation. These grips are specified in an ACS System to avoid installation delays associated with not having the proper grips on site. When using these grips, the cable may be pulled without stripping the covering off.

Each grip consists of a pulling grip and a rotating clevis connector. The pulling grip is appropriately sized to the conductor outside diameter (O.D.) and features double weave with the rotating clevis connector.



Part Number	Cable Diameter Range (in)	Rated Load* (lbs)
PGA-038-074-01	0.380 – 0.740	2,500
PGA-075-099-01	0.750 – 0.999	1,360
PGA-100-149-01	1.000 – 1.500	1,980
PGA-150-199-01	1.500 – 2.000	3,280
PGA-200-249-01	2.000 – 2.500	5,440

*Hendrix recommends installation tensions do not exceed 1,500 lbs

MSG-PULL-GRIP-ASY

Messenger Pulling Grip Assembly



Description:

Hendrix messenger pulling grip assemblies are used to connect the messenger to the lead line.

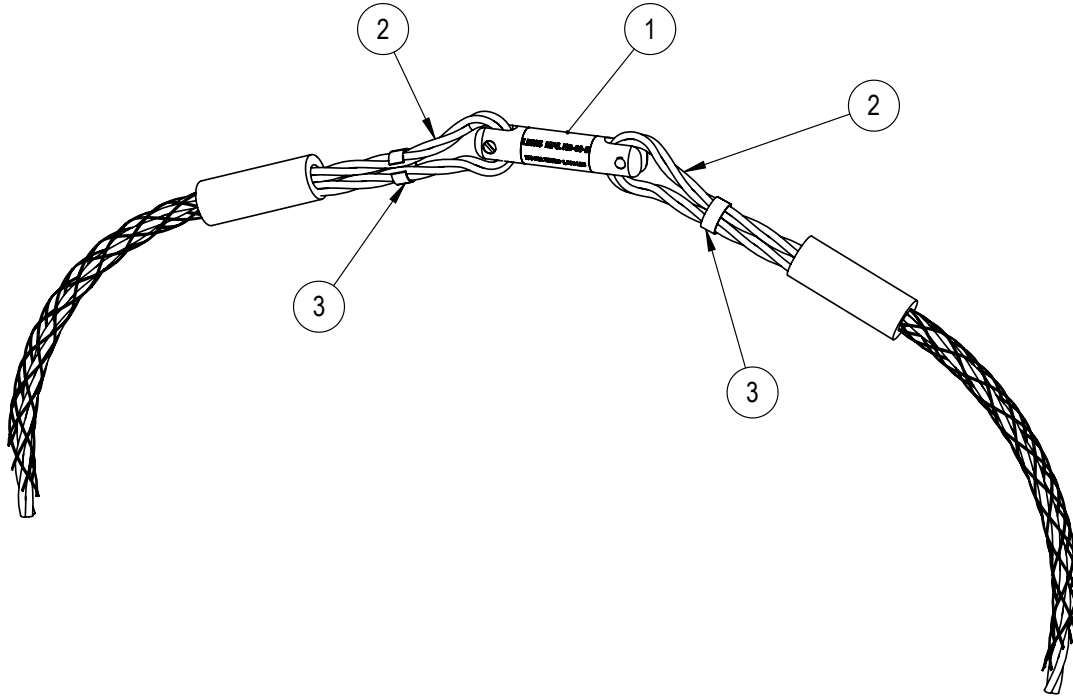

Item	Part Number	Description
1	SWIVEL-01	Swivel, Ball Bearing, Sealed Directional Boring, 4-1/4 x 5/16, PIN DIA. 3/8"
2	BASKET-GRIP	Basket Grip, Double Weave, 18" LNG, 0.38" to 0.74" Messenger, RBS 5,000 LBS. (DCD P/N 00670-038)
3	PINCH-LOCK-CLAMP	Clamp, Punch Lock, 13/16 ID, 3/8" Band (P-T Coupling P/N P3S, or similar)

*It is compatible with messenger diameter 0.34" - 0.75" and the rated load is 5,000lbs.

AMB Aerial Messenger Bucket



Description:

The Aerial Messenger Bucket is a personnel platform that is designed to provide a safe, stable means of installing Hendrix spacers in spans not accessible to bucket trucks.

Benefits:

- Ideally suited for river and highway crossings as well as remote or back lot circuits
- A safer alternative to bosun’s chairs and lineman’s ladders
- Lightweight design conforms to OSHA 29CFR 1926.550
- Transport to hard to reach locations is facilitated by the integral wheels
- Balanced lifting points permit hoisting into the operating position
- Quick release messenger retention system allows operator to roll over tangent brackets
- Patented test weight system enables the line crew to quickly and easily verify the capacity of the span installations. clearance problems when over-building existing utilities and at road crossings

Application:

Hendrix offers the AMB on a rental basis only. Those interested in purchasing an Aerial Messenger Bucket should contact Hendrix to obtain contact information for the AMB manufacturer. The Aerial Messenger Bucket is intended for use only on de-energized, properly grounded circuits. A comprehensive instruction manual is supplied with each AMB.

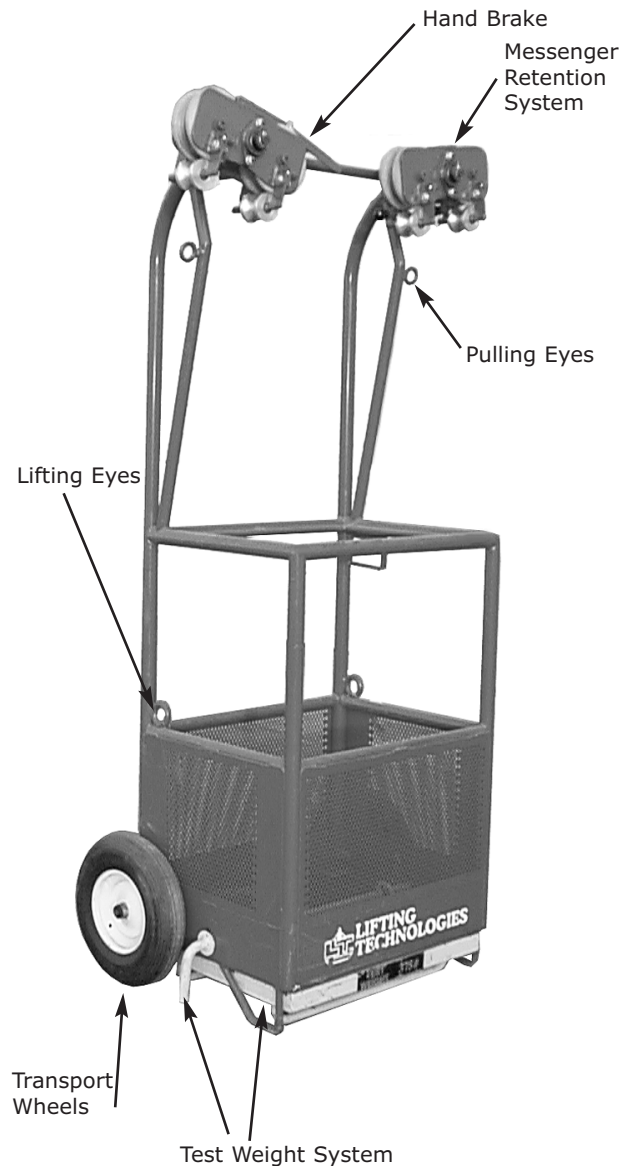

Part Number	Model Number	Gross Weight (lbs)		Maximum Rated Capacity (lbs)	Maximum Occupancy	Overall Height (in)	Overall Width (in)
		w/ test weight	w/o test weight				
AMB	MPI-300	580	205	300	1 person	89	26.5

SG-1 Sag Gauge



Description:

- Used to set the proper conductor sag during spacer cable installation
- Hung on the messenger at the mid-point between roll-by blocks (PBR-3-DR)
- When sagging, align the top of the cable to the slot marked with the current ambient temperature

Benefits:

- Instant verification of proper conductor sag
- Hot stick operable
- Light weight anodized aluminum (made from aluminum 5052-H32)
- Large, easy to read lettering
- Makes installations simpler and faster

Dimensions:

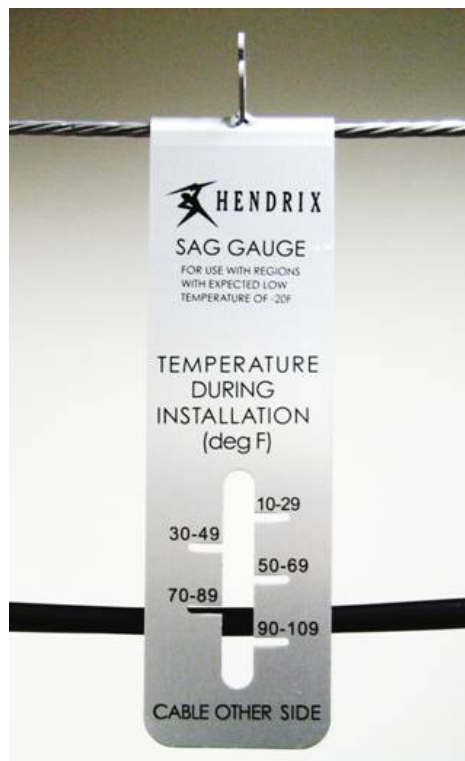

Part Number	Dimensions (in)			Weight (lbs)
	Length	Width	Thickness	
SG-1	23	6	.1875	2.5

*SG-2 available with metric units

ACS-EQP-Trailer-01 Aerial Installation Trailer



Description:

A unique racking system that accommodates organized, easy equipment access and efficient transportation.

- Dimensions: 16'L x 7'8"W x 7'8"H
- Dual Axle, Pintle Hitch
- Electric Brakes for both axles
- Easy access side door 32" X 60"
- Special designed racks built for equipment
- 3 year warranty

Benefits:

- Fork Lift compatible for easy on-off flatbed loading
- Efficient transportation to & from job sites

Part Number: ACS-EQP-Trailer-01



Pintal Hitch



Fork Truck Lifting Tubes



The Hendrix Difference

Hendrix offers a complete solution, or a customized subset of products and services that solves the problem a customer faces.

- **Increased Reliability**
- **Improved SAIDI & SAIFI Indices**
- **Withstands Harsh Environments**
- **Multiple Circuits on a Single Pole**
- **Improved Voltage Reduction by 20%**
- **Unlimited Span Lengths**



Ideal for express circuits. Hendrix Aerial Cable Systems can improve downstream voltage by approximately 20%.

Hendrix provides fully supported aerial cable solutions for 15kV, 25kV, 35kV, 46kV, 69kV, 115kV, and 138kV.



Our goal is to maximize system circuit reliability and installation efficiency. We offer a complete solution, or any customized subset of products and services that achieves this goal.

