

## Description:

Hendrix tap wire is a copper conductor covered with a 0.150" layer of flexible, black, thermoplastic elastomer. It provides a covered lead from primary phase conductors to equipment bushings.

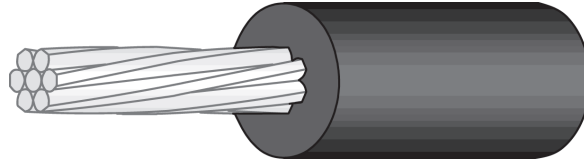

## Benefits:

- Tap wire will reduce or eliminate outages due to wildfire contact
- Excellent ultraviolet and weathering characteristics maintain covering integrity
- Thermoplastic elastomer covering is more flexible and trains easier than polyethylene covering

## Application:

Hendrix covered tap wire is used to connect an overhead phase conductor to equipment bushings. Using covered tap wire avoids outages due to wildlife contact with the energized tap and another phase or a ground plane such as a transformer case. Covered tap wire is commonly used with the Hendrix Wildlife Guard which is placed over the bushing and isolates the bushing connector from contact. The tap wire can also be used in substation equipment connections to provide covered bus and as covered ground lead.

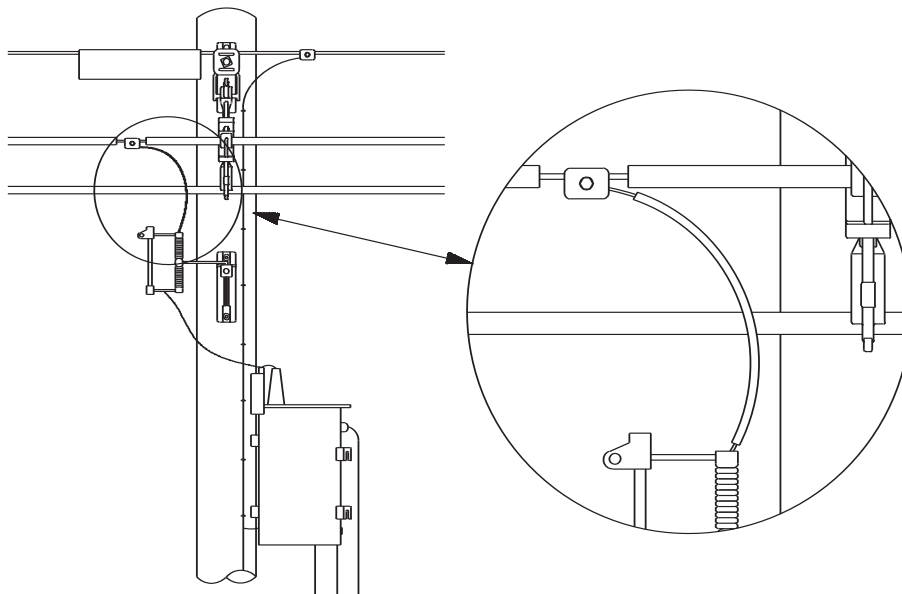

Part Number	Size	Strands	Conductor Diameter (in)	Conductor Thickness (in)	Overall Diameter (in)	Weight (lbs/ft)	Normal Ampacity with Sun/Wind* (amps)
TAP06CUSOL	#6 AWG	Solid	0.162	0.150	0.462	0.143	162
TAP06CUSTR	#6 AWG	7	0.178	0.150	0.478	0.145	162
TAP04CUSOL	#4 AWG	Solid	0.204	0.150	0.504	0.212	209
TAP04CUSTR	#4 AWG	7	0.232	0.150	0.532	0.214	209
TAP02CUSTR	#2 AWG	7	0.283	0.150	0.583	0.290	281
TAP10CUSTR	1/0 AWG	19	0.362	0.150	0.662	0.428	372
TAP40CUSTR	4/0 AWG	19	0.512	0.150	0.812	0.783	569

\*105°C Conductor temperature; 25°C Ambient Temperature; Sun; 2ft./sec Wind