

# PSAC-01 Permanent Stringing Angle Clamp



## Description:

The PSAC is a combination stringing block and messenger clamp. The PSAC allows the messenger wire to be pulled in, tensioned and clamped using one piece of hardware. The PSAC saves significant time and labor when installing messenger wire at angle poles.

## Benefits:

- Acts as a stringing block to install messenger wire
- Built-in clamp secures the messenger once it is tensioned
- Saves time by eliminating the need to relieve messenger tension, removing block and install messenger clamp
- High strength design will support the largest size spacer cable systems on large angles
- Safer for line workers because messenger is never removed from the device

## Application:

The PSAC is designed to be attached directly to the pole with an eye bolt. The PSAC can also be attached to the BA4-15 or BA4-35 bracket for angles that pull away from the pole. The PSAC is recommended for line angles to 60°. The PSAC is designed for pulling grips and swivels up to one inch diameter.

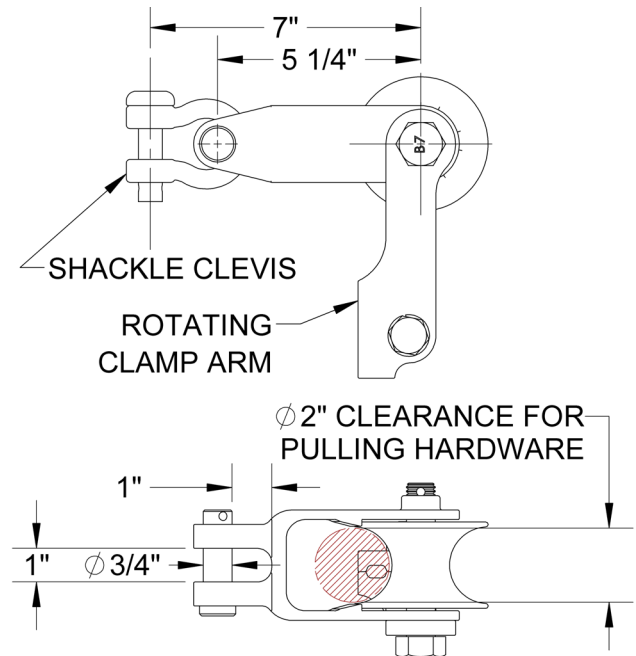
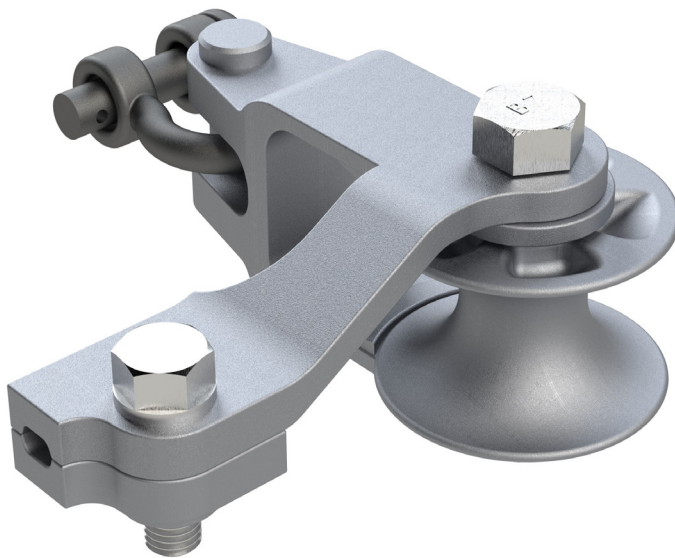

Part Number	Weight (lbs)	Maximum Load Rating (lbs)	Material
PSAC-01	9.00	20,000	HDG- Cast Steel