



## Description

Designed for 15-46kV distribution voltage, the RTL-46 is a three phase spacer used in Hendrix Spacer Cable Systems. Mounted on a messenger wire, the RTL-46 will support and separate the messenger and phase conductors in a diamond configuration. The RTL-46 uses ratcheting clamps to secure the messenger and conductor. Hendrix spacers are molded using a proprietary gray track resistant and UV resistant high density polyethylene material.

## Benefits

- ◆ Designed for easy and efficient installation and replacement
- ◆ Integral ratcheting clamps secure our full range of messenger and phase conductor sizes
- ◆ Wedge-shaped messenger hook provides maximum grip
- ◆ Optimum dielectric compatibility with Hendrix Spacer Cable
- ◆ Excellent weather washing characteristics
- ◆ Long leakage distance resists flashovers
- ◆ Phase spacing minimizes voltage drop
- ◆ Highly resistant to shock/impact/rifle fire
- ◆ Open diamond design provides neat appearance
- ◆ Can be installed with hot line tools
- ◆ Molded from proprietary gray track resistant and UV resistant high density polyethylene material

## Application

Use the RTL-46 in three phase distribution systems rated up to and including 46kV, phase to phase. Installation of the spacers should be made in accordance with the appropriate Hendrix Aerial Cable System Instructions.

Mount spacers at 30 foot intervals. Fasten to the messenger and conductor with the ratcheting clamps.

To eliminate swaying at poles, use the lower hole on the backside of the spacer for Anti-Sway Brackets (BAS-24F, supplied separately).

# RTL-46

## Technical Specifications

### Electrical Values

Minimum Leakage Distance (in): 17-3/4  
Maximum System Voltage (kV): 46  
Short Circuit Rating (kA): 16.0\*

### Dimensions

Max. Messenger Size (in): 0.750  
Max. Conductor Size (in): 2.0  
Overall Dimensions (in): 26 x 16-1/2 x 3-1/4

### Other

Weight (lbs): 4.00  
Material: High Density Polyethylene

## Additional Information

- ♦ \*Calculated values for short circuit rating
- ♦ For steep grade applications (greater than 20°) specify RTL-46DM
- ♦ Reduce spacer intervals to 25'-0" when supporting 954 kcmil or larger cable size

## Dimensions

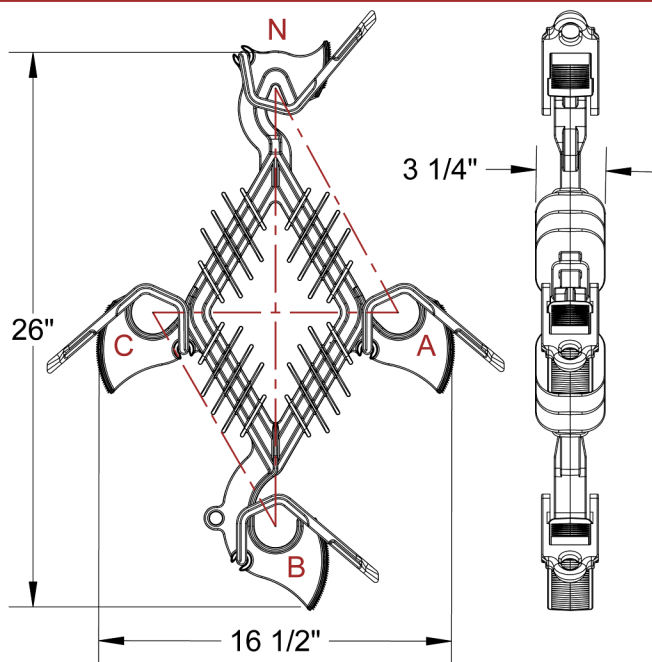

## Application

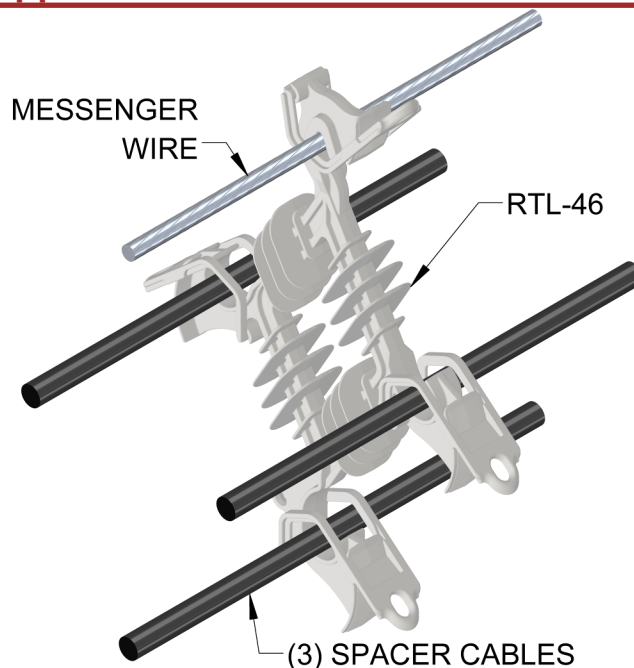

Catalog No	Phase Spacing (in)			
	AN	AC	BC	BN
RTL-46	12	11-1/2	11-1/2	20-1/2

R00