

Description

Designed for distribution voltages up to 46kV, the BM-24 is a tangent pole bracket used in Hendrix Spacer Cable Systems. This bracket is formed from cast ductile iron and hot dipped galvanized after fabrication. The BM-24 is equipped with a messenger clamp for secure fastening of the messenger to the bracket. This bracket features equipment mounting holes for use with the Roll-by Method installation equipment.

Benefits

- ◆ Designed to work in conjunction with Hendrix Roll-By installation equipment
- ◆ Allows for continuous, uninterrupted pulling past tangent structures
- ◆ Tangent brackets are designed for "back to back" double circuit construction
- ◆ Compatible in both single and three phase Hendrix Spacer Cable Systems

Application

Use the BM-24 bracket on tangent poles (line angles 0-6°) in distribution systems rated up to and including 46kV. Mount to the pole with two (2) - 3/4" thru-bolts (not supplied). Secure the spacer cable messenger wire with the messenger clamp. The Tangent Stirrup, TS-1 (supplied separately) is attached at tangent poles for hanging spacers below the bracket.

Single phase pole assemblies may use this bracket on angle poles.

Tangent brackets can be used for supporting spacer cable on pin top insulators. There is hole on the bracket to place a Short Shank Insulator pin.

BM-24

Technical Specifications

System Application

Bracket Type: Tangent Msg
Bracket Shape: 24
Maximum System Voltage (kV): 46
Line Angle (degrees): 0-6

Dimensions

Overall Dimensions (in): 10 x 24 x 4

Other

Material: Ductile Iron
Finish: HDG
Weight (lbs): 20.50

Additional Information

- ♦ Mounting bracket to a flat surface requires the Aluminum Shim Plate, AL-SHIM-24 (supplied separately).

Dimensions

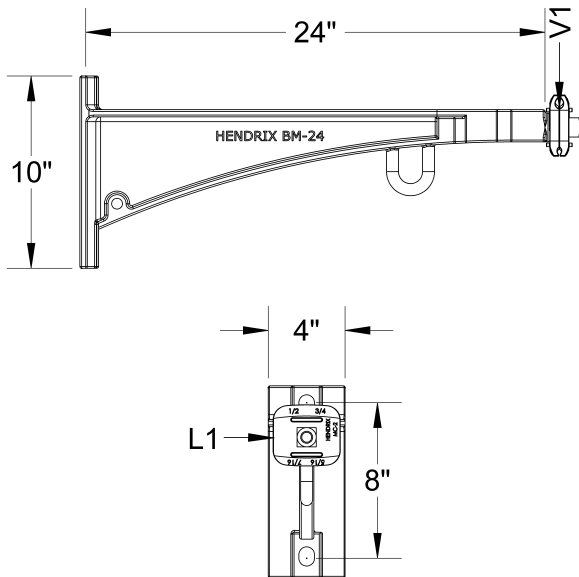

Application

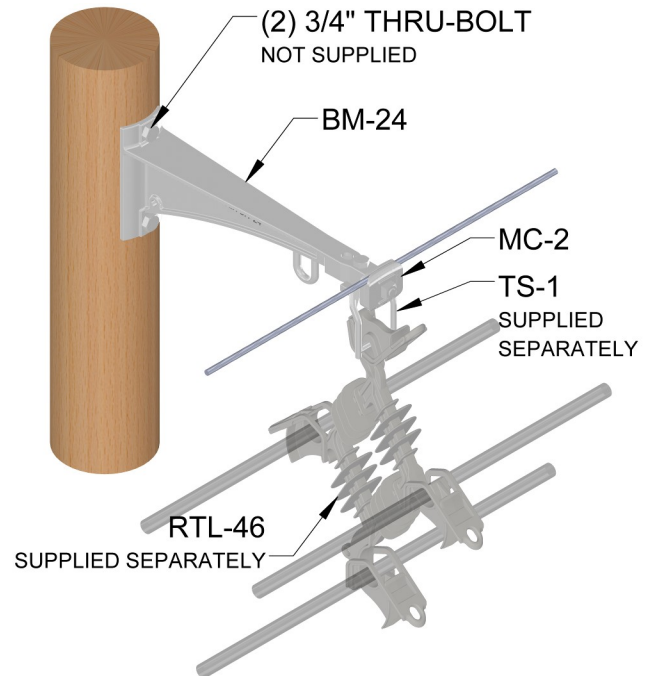

Catalog No	Maximum Capacity (lbs)	
	Vertical	Longitudinal
	V1	L1
BM-24	6000	2300