



Description

Designed for distribution voltages up to 46kV, the BAS-24F is an anti-sway bracket used in Hendrix Spacer Cable Systems. This bracket is mounted below a tangent bracket and to the backside of an spacer to stabilize the spacer movement at a tangent pole. The BAS-24F will secure the bottom of the spacer with a molded Clevis Pin (supplied). Hendrix anti-sway brackets are molded using a proprietary gray track resistant high density polyethylene material.

Benefits

- ◆ Reduces excessive swinging of the Spacer Cable System
- ◆ Stabilizes the spacer at equipment tap poles
- ◆ Minimizes flexing of the transformer lead wire and stress on connections
- ◆ Compatible in both single and three phase Hendrix Spacer Cable Systems
- ◆ Increased leakage distance for contaminated areas

Application

Use the BAS-24F Anti-Sway bracket on tangent poles (line angles 0-6°) in distribution systems rated up to and including 46kV. Anti-sway brackets should be used to stabilize spacers.

Mount the bracket to the front of the pole, directly under a tangent bracket. A stirrup is required to hang a spacer from a tangent bracket. Fasten to the pole with one (1) - 1/2" lag-bolt (not supplied).

Secure the bottom of the spacer to the anti-sway bracket with the provided molded Clevis Pin.

BAS-24F

Technical Specifications

System Application

Bracket Type:	Anti Sway
Bracket Shape:	24"
Maximum System Voltage (kV):	46
Line Angle (degrees):	0-6

Dimensions

Overall Dimensions (in): 3-3/4 x 23 x 2

Other

Material:	High Density Polyethylene
Finish:	HDG
Weight (lbs):	1.30

Additional Information

Dimensions

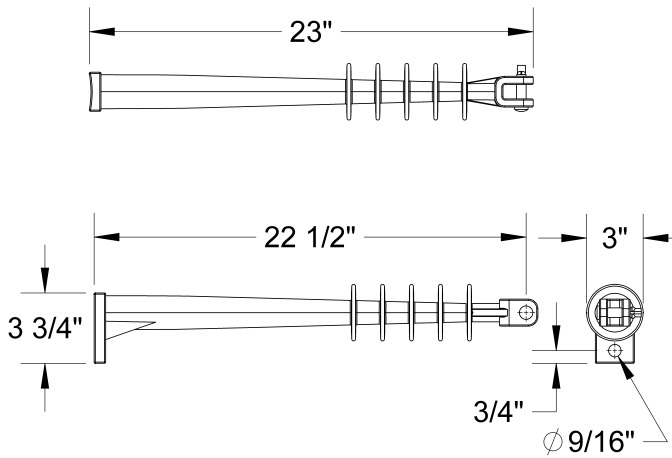

Application

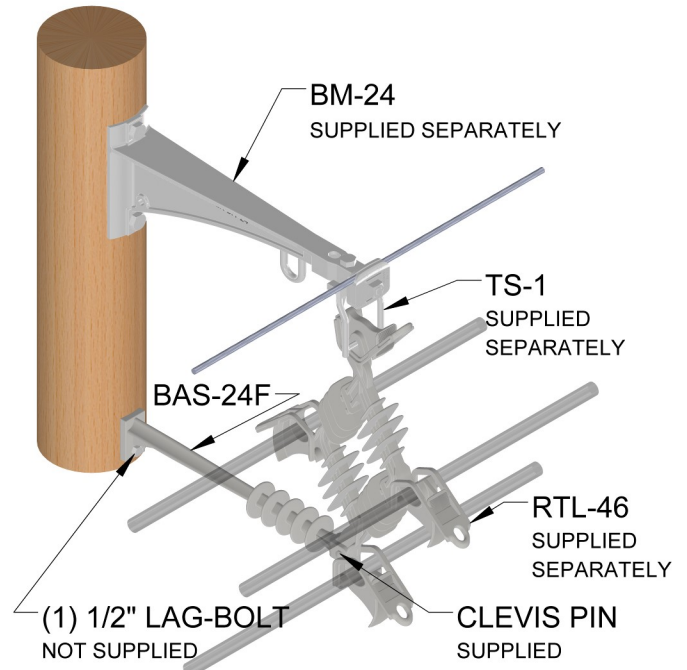

R00